



Thousands of parts & accessories for your classic

CLASSIC MINI



PERFORMANCE UPGRADES



Page A05

X-flow cylinder head
Add power to the A-series



Page A22

CSI-Ignition distributors
A breakthrough for classic ignition

CLASSIC LINES



Page A43

Iconic Mk1 grille
Essential for retro styling



Page A49

Retractor reel harness
Safe, stylish and practical

RESTORATION

Keeping the great marques alive

Extensive technical information Page 04

Detailed schematics to aid restoration Page 12





PEACE OF MIND... WARRANTY

It's simple, if you change your mind for any reason, all uninstalled parts still in their original condition and packaging may be returned to us within 90 days from the date of purchase for a full refund. A copy of the original invoice or picking label must accompany the return. Return freight is paid by the customer, unless returned due to our error.

In the event of a part failing in use, all parts are warranted against defects in materials and workmanship for 12 months from the date of purchase. Please remember that all returns must be accompanied by the original invoice, return freight will be reimbursed. For more details see our website or contact your local branch.

SHIPPING & DISPATCH

Orders for delivery in the UK may be dispatched by regular post (for small/lightweight items), or through a Next Day courier. Please contact us for the best delivery option for your order and the latest delivery prices.

For delivery outside the UK we offer the following services: Economy delivery (by road): 2 to 5 days, Express delivery (by air): 1 to 2 days (Guaranteed) - next day service to most countries and for small and low value orders we also use airmail. For these services, please ask for prices and the best delivery option when you place your order. Most deliveries (except airmail) are 'trackable', (inc: e-mail updates and internet access for selected carriers). Please remember, all carriage charges are dependent on weight band, volume, destination and delivery time. If a quotation is required prior to placing your order, please contact a member of the sales department. Alternatively, you can arrange your own delivery and dispatch.

Is your order over £600 (ex vat)?

If so, we will deliver it to a Mainland UK address free of charge!



PRICING

Due to the volatility of world markets and currency fluctuations the prices in this catalogue are subject to change. **Moss make every attempt to keep prices competitive and stable, however in common with all other suppliers in our industry, we reserve the right to alter prices without prior notice. For the latest prices, please call or visit our website moss-europe.co.uk.**



All prices are per unit (unless otherwise stated) and include (UK) VAT at 20% (where applicable). Please note EU countries may be charged at their local VAT rate, countries outside the EU will not be charged VAT. See the ordering information or our website for further details. Prices are correct at the time of going to print, postage & packaging is not included. E&OE.

OPENING TIMES

Open Monday to Friday

9.00am to 5.30pm

Saturday

9.00am to 1.00pm
(Closed Sunday & Bank Holidays)



Why not reserve and collect your order in person from one of our four branches?

All you have to do is send an email to sales@moss-europe.co.uk with the title of "Branch Collection", your e-mail must contain the following information:

Your full name, address, daytime contact number, desired branch for collection and part numbers.

A member of our sales team will contact you shortly after to let you know that your email has been received.

They will then contact you again when your order is ready to collect. You will then be able to collect your order any time during store open hours from the store stated in your email. On collecting your order you may be asked to confirm your address.

ORDERING

Remember, supplying details of your car, (i.e: engine, commission or VIN, LHD / RHD, year and any modifications) will save time and help us process your order correctly. We will be pleased to provide a full parts quotation, detailing price, availability and shipping costs, upon request.

Hello

INTERACT

Join us on Facebook and Twitter to keep up to date with our latest news and tell us yours.



FACEBOOK
[facebook.com/mosseurope](https://www.facebook.com/mosseurope)

TWITTER
twitter.com/mosseurope

WEBSITE
moss-europe.co.uk



LONDON

LONDON

Unit 16, Hampton Business Park
Bolney Way, Feltham
TW13 6DB

London Tel
+44 (0) 20 8867 2020

E-mail
sales@moss-europe.co.uk

Fax
+44 (0) 20 8867 2030



BRADFORD

BRADFORD

Unit 12-13, Acorn Park Ind. Est.
Otley Road, Shipley
BD17 7SW

Bradford Tel
+44 (0) 1274 539 999

E-mail
bradford@moss-europe.co.uk

Fax
+44 (0) 1274 539 990



BRISTOL

BRISTOL

1-3 Elton Street
Bristol
BS2 9EH

Bristol Tel
+44 (0) 117 923 2523

E-mail
bristol@moss-europe.co.uk

Fax
+44 (0) 117 942 8236



MANCHESTER

MANCHESTER

111-117 Stockport Road
Stockport, Cheshire
SK3 0JE

Manchester Tel
+44 (0) 161 480 6402

E-mail
manchester@moss-europe.co.uk

Fax
+44 (0) 161 429 0349



PARIS

NEW BRANCH

PARIS

7 rue Chaponval
ZAC du Cornouiller
78870 Bailly, France

Paris Tel
+33 (0) 1 30 80 20 30

E-mail
sales@moss-europe.fr

Fax
+33 (0) 1 30 80 21 50

A	Dummy filler neckA35	Lamp coversA40	Sun visorsA54
Adjusta ride kitsA28	Duplex gear setA05	LampsA36	Superpro bush kitsA29
AerialsA56	DVDsA59	Lightweight flywheelsA11	Suspension cone compressorA57
Air filtersA23	DynamatA51	Limited slip differentialsA12	Suspension kitA28
Air vent setA47	E	Lower armsA27	T
Alarm & immobiliserA45	Edge trim finisherA55	M	Tax disc holdersA49
Alloy top capA04	Electric window kitA45	Magic pipeA16	Thermal mugsA57
AshtraysA47	Engine steady bushesA08	Magnetic oil trapA11	Throttle linkagesA13
B	Engine steady kitA08	Manifold gasketA16	Throttle pedalsA49
BadgesA40-41	Exhaust insulationA16	Mirror (interior)A47	Tie barsA27
Battery cut of switchesA25	Exhaust manifoldsA15	MouldingsA30	Tower boltsA28
Bezel toolA57	Exhaust systemsA17-19	MudflapsA38	Tread platesA49
Bonnet hingesA32	F	N	T-shirtsA57
Bonnet release kitA49	Flat top pistonsA04	Number plateA32	U
Bonnet strapsA32	Flywheel pullerA57	O	Under felt kitA52
Books & manualsA59	Footwell light kitA45	Oil catch tanksA10	Union flagA59
Boot trimA54	Footwell matsA55	Oil cooler radiators & kitsA10	Union flag mouse matA59
Boot handlesA32	Fuel capsA35	Oil cooler thermostatsA10	V
Brake drumsA27	Fuel pump inertia switchA25	Oil filtersA23	Valve spring setsA05
Brake hosesA26	Fuel pumpsA25	Oil pick up pipeA11	Valves & guidesA05
Brake master cylinderA26	G	Oil pumps & valvesA10	W
Brake padsA26	Gauges & accessoriesA46-47	Oil temperature gauge adaptorA10	Wheel arch sets/kitsA38
Brake partsA26	Gear kitsA11	P	WheelsA39
Brake servo kitA27	Gear knobsA51	PatchesA57	Wind deflectorsA32
Bumper & overrider kitA31	Gear lever gaiterA52	Pedal box assemblyA08	Window moduleA45
C	Gear lever gaiter finisher kitA50	Piston ring setA04	Windscreen wiper kitsA31
Cam followersA05	GearboxesA11	Pro start push buttonA45	Windscreen washer systemsA31
Cam gear locating keyA04	General switchesA35	Q	
Camber bracketsA28	GrillesA43	Quick shift gear kitsA11	
Camber gaugeA57	H	R	
Camshafts & accessoriesA07	Handbrake gripA47	RadiatorsA09	
Car coverA57	Handbrake quadrantA27	RadiosA56	
CarburetorsA12	Head gasketsA08	Ram pipesA23	
Carpet setsA52	Headlamp accessoriesA35	Rear hubsA27	
Central locking kitA45	Headlamp conversion kitA37	Rear silencer fittingsA16	
Centre consolesA44	HeadlampsA37	Red start buttonA45	
Chassis platesA40	HeadliningA54	Rocker assembliesA07	
Cigar lighterA49	Headlamp relay kitsA37	Rocker cover & fittingsA08	
ClutchesA11	Heat shieldsA16	Rocker shaftA07	
Coil clamp & coverA20	Heated windscreens & wiring kitA30	S	
Coil over kitA29	Heater tapA09	Seal belts & harnessesA48-49	
Coil spring conversionA28	HornsA32	Seat runnersA49	
Con rodsA04	HT leadsA20	Seats & framesA54	
Cooling fan kitsA09	Hub capA39	Service partsA60-62	
Cooling fansA09	I	Shock absorbersA29	
Cross Pin differentialsA12	Ignition lead numbering setA20	Silicone hosesA09	
Cup holderA50	Ignition systemsA22	SmartScreen wash/wiperA30	
Cylinder headsA05	Indicator lens kitsA36	Solid rocker spacer setA07	
Cylinder head stud kitA07	Inlet manifoldsA13	Spark plugs & terminalsA20	
D	Interior trimA55	SpeakersA56	
Dash kitsA44	K	Stage one tuning kitA15	
Dash liner kitsA55	Key fobsA57	Starter motorsA12	
Dashpot coversA12	Keyless entry kitA45	Steering column drop bracketA49	
DecalsA40-41	Klingersil gasketA08	Steering wheel bossesA50	
DistributorsA20/22	L	Steering wheelsA50-51	
DipsticksA11	Lamp brackets & switchA35	Subframe mountingsA28	
Door handle escutcheonsA32	Lamp conversion kitsA36	Sump guardA30	
Door handles (exterior)A32			
Door handles (interior)A47			
Door mirrorsA33			
Door pocket trimA55			

Sections

Performance	A04
Exterior	A30
Interior	A44
Personal	A57
Service Parts	A60

black & white

Restoration Section

Restoration Parts	01
Ordering Information	02



Moss Europe Ltd are proud to support the FBHVC

The Federation of British Historic Vehicle Clubs exists to uphold the freedom to use old vehicles on the road.

CM-14A ©Copyright Moss Europe Ltd, March 2014. Printed in the U.K. All rights reserved. No part of this publication may be reproduced, stored in a retrieval system, or transmitted in any form by any means, electronic, photocopying, recording or otherwise without prior written consent of Moss Europe Ltd. Please note: Product colours may vary slightly to samples featured in this catalogue, due to the limitations of colour printing.



Building a retro replica?..

Here are a few retro parts from the catalogue to help you recreate that style and transform your Classic Mini.

Engine

- Alloy cylinder head (bare)451-875£797.95
- Roller rocker kit 1.5:1 1275ccTMG10848 ..£669.95
- Duplex vernier gear kit A SeriesTMG10828 ..£164.95
- Kent camshaft rally pin A SeriesKMD286P ..£113.95
- Manifold gasket 1275cc large portTMG10836 ...£3.95
- Competition copper head gasket 1275ccAHT188£23.30
- Kent 11 stud + nut set compMGS10864 ..£174.95

Cooling

- High flow alloy rad (side mount)MT3104 ...£255.95
- Revotec fan kit (side mount rad)RFK80£192.95
- 13 row oil cooler heavy dutyARA221X ...£119.95
- Oil cooler stainless steel pipes (1985 on)OCHK106 ...£53.95

Transmission

- Straight cut gear kit A+CSTN77£542.95
- LSD 45/45 ramp rallyCAJJ3387A ..£551.95

Electrical

- 12v sports coilTT2981£22.94
- High torque starter motor (inertia type)GXE4404X ..£187.94
- High torque starter motor (pre-engaged type) ..GXE4527X ..£187.94

Exhausts

- RC40 sport exhaust (fits MT6101)GEX40RC£59.95
- Freeflow manifold CooperMT6101£79.96

Lamps

- Period boot lamp 576 fogBHA4399 ...£72.95
- Chrome spot lamp Cooper (pair)GAC4610 ...£42.47
- Chrome stone guard (pair)GAC8000X ...£9.95

Brakes

- Alloy Superfin brake drum (pair)MT1210£89.95
- Mintex M1144 pads 8.4" discSTR5051£50.95

Suspension

- Adjustable lower arm rose-joint (pair)C-AJJ3363 ..£101.95
- Adjustable camber rear bracket (pair)WPT90021 ...£36.46
- Spax front stand. height (each)GAC84011X ..£59.95
- Spax rear stand. height (each)GAC84031X ..£58.25
- Heavy duty adjustable front tie bar (pair)WPT9003X ..£25.96

Exterior

- Stainless steel sump guardMT1207£57.95
- Wheel arch set group 2 for 6JMRAC402 ...£49.96
- Works bonnet strap tan222-729£13.94
- Lucas spot/fog lamp cover - black (each)162-705£44.95
- Heated laminated windscreen (Monte Carlo) - clear .24A2236HM £247.96

Interior

- Full harness red 3 pointSBH605RED ..£39.80
- Full harness red 4 pointSBH655RED ..£45.85



CAJJ3382/40

Flat top pistons

These pistons are made from lightweight alloy AE109TF specification with two heat treatments. They are designed for durability yet lightweight and have a crown thickness 1.2mm thicker than other leading pistons. Ideal for machining for long stroke cranks. Sold individually complete with rings.

- Flat top pistons +20 1275ccCAJJ3382/20 ..£69.95
- Flat top pistons +40 1275ccCAJJ3382/40 ..£69.95
- Flat top pistons +60 1275ccCAJJ3382/60 ..£69.95

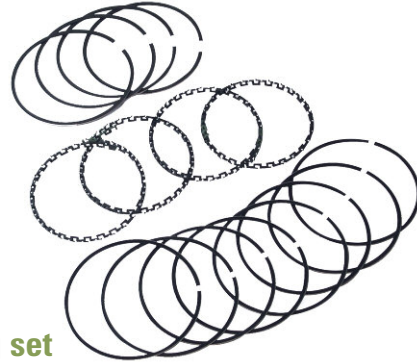

Piston ring set

Replacement piston ring sets for the pistons listed.

- Ring set +20 for 3382 +20 pistonsCAJJ3379/20 ..£69.95



Con rods for Cooper S

Reproduced to original specification, these EN24V con rods are the strongest production A series rod produced. 1.625" big end journal size with 5.75" centres.

- Con rod (each)AEG624£142.94



Cam gear locating key

These offset keys make getting the best out of your camshaft easy. Please see manufacturers data for correct timing figures.

- Cam gear locating key 1° offsetMGS108251 ...£9.25
- Cam gear locating key 2° offsetMGS108252 ...£8.95
- Cam gear locating key 3° offsetMGS108253 ...£8.95
- Cam gear locating key 4° offsetMGS108254 ...£8.95
- Cam gear locating key 5° offsetMGS108255 ...£9.25
- Cam gear locating key 6° offsetMGS108256 ...£8.95
- Cam gear locating key 7° offsetMGS108257 ...£8.95
- Cam gear locating key 8° offsetMGS108258 ...£8.95
- Cam gear locating key 9° offsetMGS108259 ...£7.96
- Cam gear locating key kit 2°, 4° & 7° offset ...MGS10725 ...£26.50



Alloy top cap

- Alloy top cap (each)TMG10816 ...£13.20
- (Half the weight of steel).



Duplex gear set

It is preferable to change from single row chain (simplex) to twin row chain (duplex) as the duplex is less prone to stretching. The cam timing can also be optimised via an adjustable cam gear, or via offset cam keys. Please see manufacturers data for correct timing figures.

Kent cams vernier adjustable duplex kitTMG10828 .£164.95



Valve spring sets

Dual spring set 200lbs - road useTMG10807 .£35.40

Dual spring set 250lbs - race useTMG10808 .£122.95



CAEG579

Lightened cam followers

Lightening the valve train helps improve engine response. Our lightened cam followers weigh just 40g and come with an oil drain hole.

Lightened cam follower (each)TMG10709 .£6.46

Lightened cam follower setCAEG579 .£33.95



Valve guides

Bullet shaped valve guides allow better flow without loss of durability. Bronze alloy valve guides are required when fitting EN214N steel valves.

Bronze valve guide set (set of 8)TMG10819 .£47.95

Iron valve guide tapered nose (each)12G1963 .£1.80

Top hat seal (Rover valve stem oil seals)ADU4905 .£0.55

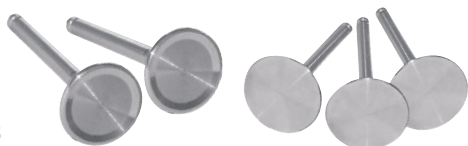

Valves

Our competition valves are produced in EN214N steel and require installation with bronze valve guides (TMG10819). They are single groove collets (88G459).

Inlet valve 35.6mm high flow 1275cc (EN214N) .CAEG544 .£18.25

Inlet valve 37.2mm high flow 1275cc (EN214N) .CAHT55 .£Call

Exhaust valve 29.4mm high flow 1275cc (EN214N) .CAEG106 .£14.15

Rimflow valves are considered to be the best valves on the market. Produced in EN214N steel but they have chromed plated stems to enable them to be installed with iron guides although we recommend bronze guides as these help with heat dissipation. Rimflow valves use single groove collets (88G459).

Rimflow inlet valve 35.6mm 1275cc (EN214N) .MST2021 .£23.45

Rimflow inlet valve 36.57mm 1275cc (EN214N) .MST2022 .£Call

Rimflow exhaust valve 31mm 1275cc (EN214N) .MST2012 .£22.40

Valve 'Cotter' (2 per valve)88G459 .£2.95

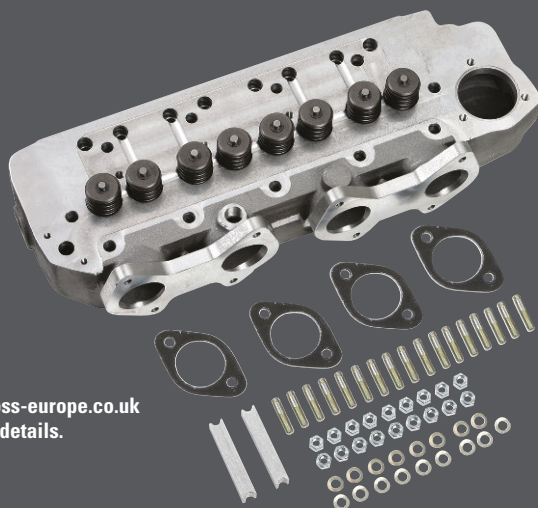

See moss-europe.co.uk for full details.

Alloy cylinder head - cross flow

Add power to your A Series with this 7 port crossflow aluminium cylinder head. The cross flow design and larger inlet ports overcome the Siamese head's breathing restrictions providing as much as 25% prior to further modification. The cylinder head is lighter weight and features an integrated cast inlet manifold (for DCOE carbs or throttle bodies); has an increased air flow rate; runs cooler and allows for higher compression ratios. Special spark plugs are required.

Alloy cylinder head - cross flow assembled451-808 .£1050.30

(Assembled with valve guides, seats, valves & springs)

Alloy cylinder head - cross flow bare451-807 .£954.30

(Fitted with valve guides & seats)

Spark plug - NGK (each)ER9EH .£14.10



Alloy cylinder head - 5 port

Alloy cylinder heads are an excellent alternative to the original cast iron unit as they are lighter and manufactured with design improvements. The water jacket has been improved to prevent the creation of hot spots and the valves are repositioned to allow up to 38mm inlet and 32mm exhaust valves. Special spark plugs are required.

Alloy cylinder head - 5 port assembled451-876 .£917.95

(Assembled with valve guides, seats, valves & springs).

Alloy cylinder head - cross flow bare451-875 .£797.95

(Fitted with valve guides & seats).

Spark plug - NGK (each)451-890 .£14.10



Stage 3 iron cylinder head - 5 port

Cylinder head assembly Stage 3 unloaded, ports enlarged and chambers reshaped new 35.6mm inlet and 31mm exhaust, bronze guides and Moss ST valve springs.

Stage 3 iron cylinder headTMG10803B .£667.94



CSI-IGNITION DISTRIBUTORS

...Driven by our Passion

A fully electronic ignition system built into the correct type of Lucas distributor housing to suit your Classic.



Sixteen easily switchable, optimised ignition curves allow timing adjustment to suit your car's engine and fuel specifications. Curves are easily selected using a screwdriver in a rotary switch, with a bright flashing LED indicator to show the selected curve.

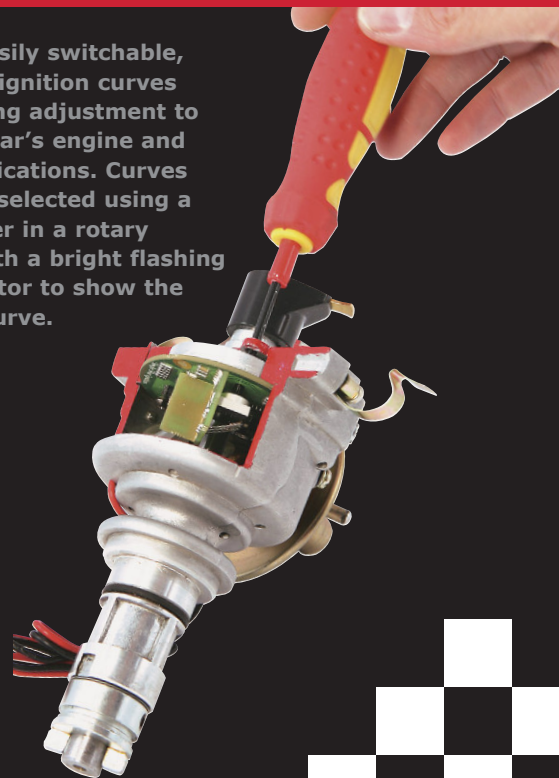

CSI-Ignition distributors offer a fully electronic ignition system built into the correct type of Lucas distributor housing to suit your Classic, keeping the original appearance in the engine bay. You can only tell the difference when you remove the distributor cap!

Gone are the points and condenser and mechanical advance mechanism, all replaced with a high quality electronic ignition system manufactured using military specification components for durability and reliability. These distributors are maintenance free (no points to adjust), and offer the benefits of, easier starting & smoother running, more torque & power, reduced fuel consumption & emissions. They also eliminate the weaknesses of mechanical timing advance and problems such as points bounce ensuring correct ignition timing throughout the rev range.

CSI-Ignition distributors are a breakthrough for classic car ignition systems

Each CSI-Ignition distributor features 16 easily switchable, optimised ignition curves to allow timing adjustment to suit your car's engine and fuel specifications. Alternative advance curves can be selected to suit your engine's state of tune making them ideal for modified engines. Curves are easily selected using a screwdriver in a rotary switch, with a bright flashing LED indicator to show the selected curve all concealed underneath the distributor cap.

A wide range of CSI-Ignition distributors are available for a variety of applications. They are supplied 'optimised' with vacuum advance to suit road or uprated cars running on SU carburettors, or 'tuned' without vacuum advance for cars running Weber type carburettors. Some units may only be available to order.



Part no. CSD1014671

See page A22 for more details of the CSI-Ignition Distributor to suit your Classic.

London	020 8867 2020
Bradford	01274 539 999
Bristol	0117 923 2523
Manchester	0161 480 6402
Paris	01 30 80 20 30
Website	moss-europe.co.uk



CLASSIC SPORT IGNITION



Cylinder head stud kit

You should consider the strength and reliability of all the critical fasteners used on your engine. Increased reliability can be obtained for mild states of tune by replacing the head studs and nuts with uprated versions. The greater strength of these studs will restrict stretching under pressure and therefore keep the head and gasket securely in place.

Kent cams 9 studs and nuts competition kitTMG10864 .£164.95
 Kent cams 11 studs and nuts competition kit . . .MGS10864 .£174.95

EN24 nickel chrome moly steel studs, competition head stud kit (11 studs, nuts & washers). This special kit was developed to replace the increasingly inconsistent standard items. The studs are manufactured in selected hi-grade steel and produced to exacting specifications. These studs do not stretch, so they pull the head down, not the thread up, this vastly increases head gasket life, even on high compression engines. Special thick washers, countersunk on one side, help clamping capability and reduce thread bottoming of the nuts.

The 12 point skirted nuts help to increase torque accuracy through better engagement. Note that even replacing the head bolt with a stud, only torque that stud to the factory recommended spec (25ft/lbs), the other studs can be torqued to 65ft/lbs with oil, 55ft/lbs with ARP lube.

11 studs and nuts competition kitAHT280£69.95



Kent performance camshafts

All the Kent camshaft applications/part numbers below with the suffix 'P' are for the original pin drive oil pump/camshaft. If you have changed your camshaft and oil pump to either 'Star' drive or 'Metro Slot', use the suffix 'S' or 'M' on the part number.

To assist in selecting a suitable camshaft we have prepared a table showing their various characteristics, these will change from engine to engine and with other modifications such as carburettor or valve size. A scatter profile is where the cam timing on No. 2 and 3 engine cylinders has been altered slightly to combat the poor scavenging of the siamese port design. This will benefit both the tickover and high end performance. The effect of a larger engine is to lower the camshaft's power range slightly.

Care must be taken to ensure that installation is carried out correctly and



Uprated rocker shaft

To enhance valve train strength and reliability especially in high revving engines.

Tuftrided rocker shaftTMG10817 . .£26.95



Solid rocker spacer set

The spacer replaces the springs reducing side loading on the rocker arms cutting resistance and creating less drag.

Solid rocker spacer set (set of 3)CAEG392 . .£15.46



AHT438

Uprated rocker assemblies

Roller rockers are stronger than the standard set up and are designed to operate the valves with less resistance, these kits also give higher lift than standard at a ratio of 1.5:1 instead of 1.3:1. Always use with uprated valve springs and check carefully for clearance.

1.5:1 ratio rocker assembly 1275ccAHT438 . .£255.95

1.5:1 ratio titan rocker assembly 1275ccTMG10848 .£669.95

that components all work together or you will not get the expected power output or reliability. It is essential that the new cam is fitted with new followers as they mate with the lobe that they run on and should never be used on another lobe.

Lightened and Tuftrided followers wear more slowly and put less load on high lift cam lobes, they are also manufactured with a drainage hole. Another essential is the special lubricant that must be used with all new cams, it provides vital lubrication during initial starting and protects your cam from extreme wear in its first minute of use.



Camshaft accessories

Don't forget the camshaft assembly lubricant or the cam timing degree disc, you will need this to set your cam timing.

Cam lubricant 250mlKEN2£6.65

360° cam timing discTT2929£5.95

Camshaft Type	Part No.	Price	Inlet Timing	Exhaust Timing	Duration Inl - Exh	Cam Lift	Description
Fast road	KMD266S	£113.95	24/56	61/29	260-270°	0.263"-0.270"	1275cc smooth idle
Road rally	KMD276S	£113.95	29/61	66/34	270-280°	0.293"-0.315"	1275cc slightly lumpy idle excellent street cam
Rally scatter	KMD286SPS	£173.95	34/66	71/39	280-290°	0.315"-0.324"	1275cc lumpy idle max street cam
Race	KMD296M	£82.96	39/71	76/44	296-300°	0.324"-0.340"	1275cc race/1380cc slightly lumpy
Race scatter	KMD296SPM	£178.96	39/71	76/44	296-300°	0.324"-0.340"	1275cc race/1380cc slightly lumpy





Alloy rocker cover and fittings

An alloy rocker cover will improve the appearance of your engine bay and, as an added advantage, will help to muffle valve train noise. Always fit a new gasket when replacing your rocker cover, and do not over tighten rocker cover nuts. We offer a range of accessories for the rocker cover including anodised T bars for a custom appearance.



- Ribbed rocker cover - polishedGAC4068P . . .£22.50
- Ribbed rocker cover - redGAC4068R . . .£33.65
- Ribbed rocker cover - blueGAC4068B . . .£33.65
- Fitting kit for rocker coverGAC4069FK . .£13.94
(Fitting kit includes: Oil cap, seals and chrome spacers/nuts/washers).
- Ribbed rocker cover kit - polishedWPA9007X . .£34.15
(Kit includes: Rocker cover GAC4068P and fitting kit GAC4069FK).

- Rocker cover knurled nuts (pair) - chromeWPA9029X . .£8.74
- Rocker cover T bars (pair) - chromeWPA9039X . .£5.05
- Rocker cover T bar (pair) - anodised blueWPA9039B . .£7.40
- Rocker cover T bars (pair) - anodised redWPA9039R . .£7.40
- Chrome filler cap8G612CP . . .£5.99
- Matt steel filler cap8G612 . . .£7.06
- Washer & grommet kitGAC4069WK . .£3.76
- Rocker cover gasketGUG705009VC . .£1.06

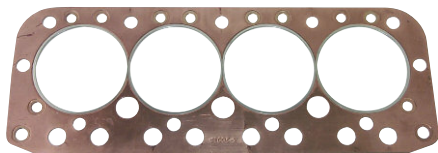

MST208

Upated head gaskets

To reduce the risk of head gasket failure on high compression performance engines it is wise to fit one of these upated, copper faced, head gaskets. The manifold gasket is to be used when the exhaust and inlet ports have been modified on 1275cc cylinder heads.

- Copper asbestos competition head gasket 1275cc AHT188£23.30
- Upated head gasket 998ccMST207 . . .£9.85
- Upated head gasket 1275ccMST208 . . .£14.95
- Competition manifold gasket large ports 1275cc .TMG10836 . .£3.95

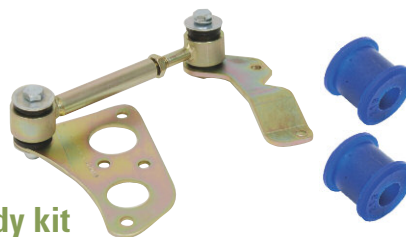

Engine steady kit

A common problem with Minis is their tendency to destroy engine mounts and steady bar bushes, leading to exhaust down pipe breakage. This is the best engine steady kit available. It mounts neatly on the top two bolts of the water pump and on to the bulkhead. It has an adjustable tie rod with rubber bushes, but can be uprated with one piece SuperPro bush. Suitable for all models including LHD cars.

- Ultimate engine stabiliser kitABR024 . . .£35.95
- Solid bush with sleeve (each, 2 per bar)CRC5329SP . .£3.94



Poly engine steady bushes

We recommend using polyurethane engine steady bar bushes as they give maximum control and are very hard wearing. We supply a polyurethane bush to fit the top RH steady bar from the engine to the bulkhead (below the master cylinders), this solid one piece bush for maximum control.
Note: Always install polyurethane bushes with grease provided.

- Solid bush with sleeve (each, 2 per bar)CRC5329SP . .£3.94



Pedal box assembly

This Mini pedal box is a lightweight mild steel under-slung design, that offers the driver the highest level of efficiency in this critical area. The ergonomic design features a fabricated lightened steel brake and clutch pedal with oil impregnated spherical bushes that sets new standards in pedal box design. This pedal box is fitted with a bias bar that operates a dual master cylinder braking system, giving total control over the braking from front to rear. Kit contains: 1 x 3 pedal Mini pedal box, with bias bar, 3 x master cylinders, 1 x clevis, 3 x reservoir, 3 x stainless steel 560mm long feed hoses, 1 x bias cable adjuster.

- Pedal box assembly (brake bias 6:1 ratio)MPB1275 . .£913.96

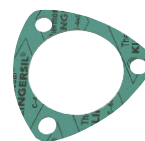

Klingersil gasket

These gaskets are manufactured from a modern high performance synthetic material that can withstand much higher temperatures (up to 400°F) and extreme pressures (up to 750psi) making them ideal for fast road and competition engines.

- Gasket thermostat housing upratedGTG101X . . .£0.95



High performance radiators

A 2 core radiator is ideal for fast road while for race applications a 4 core is best where extreme cooling is required. For the ultimate cooling use our alloy radiator, suitable for all applications due to better heat sinking through the aluminium construction and it looks great! Our special 3 core fast road radiator has been developed to include an M22 x 1.5 threaded boss in the header tank, this allows easy fitting and adjustment of the Revotec fan controller or installation of thermal switches.

- 2 core high performance radiator - fast roadGRD4442 . . .£164.95
- 2 core high perf. radiator with fan switch - fast road .GRD4443 . . .£159.95
- 3 core high perf. radiator - boss in header tank . .GRD4442TDF £71.95
- 4 core high performance radiator - raceGRD4444 . . .£129.95
- Alloy radiator (side mounted)MT3104 . . .£255.95

Fan switches for use with GRD4442TDF, MT3104 can be used to switch any electric fan on or off. Electronic fan controller (RFC010) can be adjusted for different temperatures.

- Thermo switch 82-68°IM50100 . . .£10.96
- Thermo switch 88-79°IM50120 . . .£11.05
- Thermo switch 92-87°IM50200 . . .£7.96
- Thermo switch 88-74°IM50250 . . .£8.95
- Electronic fan controller, thread fitting M22 x 1.5 .RFC010 . . .£68.95

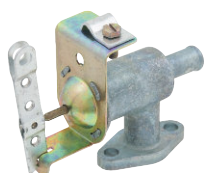

Heater tap

This is the closest you will get to an original Cooper S heater tap for that added retro look. This tap allows water to flow from the head to your heater, a perfect retro replacement if your heater taps fails.

- Heater tap (non standard)JJC10018 . . .£29.95



Cobalt silicone hose sets with clips

Upgrade the cooling system with these high quality multi-ply silicone hoses. Available in a choice of colours they include stainless steel clips, ensuring a long life. These kits fit all side mounted radiator models, except SPI and MPI. Trimming of the top hose is required to suit your car. Instructions included.

- Cobalt silicone hoses - blackMT3205 . . .£91.96
- Cobalt silicone hoses - blueMT3206 . . .£91.96
- Cobalt silicone hoses - redMT3207 . . .£91.96

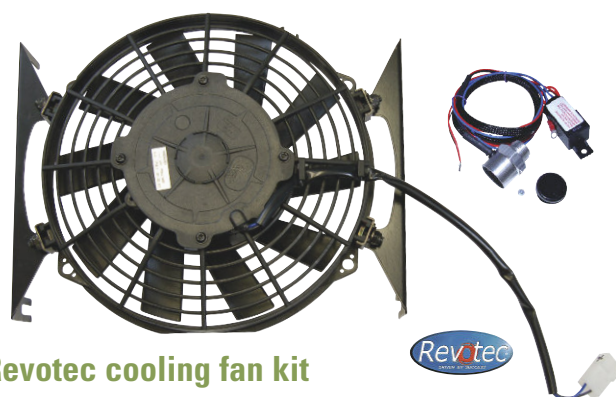

Revotec cooling fan kit

Keeping the engine of your Mini running at it's optimum temperature ensures you get the best performance and economy. Using the latest high efficiency fans with adjustable electronic controllers these kits are designed to replace the standard original mechanical fan, reducing the load on the engine and noise and improving both power and mpg.

Revotec have designed these kits using a special slim-line motor to fit neatly between the radiator and the inner wing. Unlike other fan kits that use universal mounting systems through the radiator core, this kit fits using bespoke laser cut brackets that mount directly to the radiator cowling, using existing mounting bolts. This kit is not suitable for automatic models.

The kit includes: High efficiency fan assembly, electronic controller, bespoke brackets, hardware & wiring, and full fitting instructions.

- Revotec fan kitRFK80 . . .£192.95



Kenlowe cooling fan kit

The kit includes fan, motor, thermostatic switch, wiring and mounting hardware. A manual override switch is also available separately to allow the driver to override the thermostatic switch. The fan can be used in conjunction with the standard (non-electric) fan or as a replacement for the standard fan.

- Kenlowe fan kitGAC8411X2 .£113.95
- Manual override switchTT2948 . . .£10.80
- Thermostatic variable control switch capillary type .TT2952 . . .£53.95
- Thermostatic variable control switch electronic type .TT29521 . . .£47.95
- Replacement seal for TT2952TT2947X . . .£1.80



Cooling fans

Fit a Special Tuning style two blade fan or for extra air flow use this 6 blade fan, as used on export Minis. Metal construction finished in yellow paint.

- 2 blade fan2A997 . . .£29.56
- 6 blade fan2A998 . . .£37.07





Oil cooler kits

These days we expect our cars to cope with high speeds for long periods of time, on motorways etc... These conditions stress the standard oil system of the Mini, as high engine speeds cause the oil to heat up and thin, reducing its viscosity and leading to a subsequent drop in oil pressure and possible premature engine wear. Oil cooler installation kits are available with either rubber or braided stainless steel hoses, the oil radiators themselves are sold separately. These are for non front mounted radiator models.

- Oil radiator 10 rowARO9807 ...£65.95
- Oil radiator 13 rowARA221 ...£34.96
- Oil radiator 13 row, MocalARO9809 ...£74.95
- Oil radiator 13 row heavy dutyARA221X ...£119.95
- Oil cooler kit rubber hose (to 1979)OCHK100 ...£28.96
- Oil cooler kit rubber hose (Clubman) (to 1979) .OCHK101 ...£40.96
- Oil cooler kit stainless steel hose (to 1979)OCHK102 ...£38.95
- Oil cooler kit rubber hose (1979-84)OCHK103 ...£56.95
- Oil cooler kit stainless steel hose (1979-84)OCHK104 ...£64.96
- Oil cooler kit rubber hose (1985 on)OCHK105 ...£47.95
- Oil cooler kit stainless steel hose (1985 on)OCHK106 ...£53.95



Spin-on oil filter adaptors/conversions

Fitting a spin-on filter adaptor makes changing the oil much easier and cleaner, it also prevents oil draining out of the filter giving better oil pressure on start up. Oil filters supplied separately.

- Spin-on oil filter conversion 948-1275ccGFK1001 ...£69.95
(For Tecalmit heads & Purolator heads, except casting number MIC90020).
- Oil filter - K&N Performance Gold235-830£10.96
- Oil filter - standard (for GFK1001 only)GFE166£2.75
- Spin-on oil filter conversion & hose 948-1275cc .235-875£42.95
(This spin-on conversion is suitable for all models as it replaces the filter head and pipe assembly. Ideal if filter head or pipe is damaged or missing).
- Oil filter - K&N Performance Gold235-830£10.96
- Oil filter - standard (for 235-875 only)GFE173£6.95

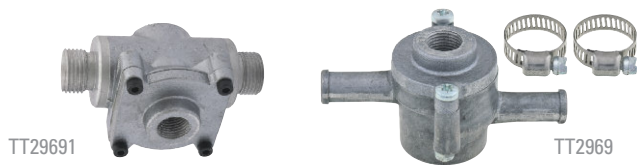

Oil temperature gauge adaptor

If you want to fit an oil temperature gauge then use one of our in line adaptor.

- Push-on temperature 1/2" adaptorTT2969£44.95
- Screw-in temperature 1/2" adaptorTT29691£75.95



Oil cooler thermostats

Use these thermostats to limit the flow of oil through the oil cooler until it has reached a temperature of 74 degrees Celsius.

The standard oil thermostat has push on connectors for use with 1/2" rubber hoses and comes with hose clips. It seals off the radiator completely until the oil is up to temperature. The full flow oil thermostat restricts flow to the radiator by allowing it to bypass through the thermostat until the oil is up to operating temperature. Use screw unions TT29602 to connect hoses to the full flow thermostat.

- Push-on standard oil thermostatTT2960£43.96
- Screw-in full flow oil thermostatTT29602 ...£132.95
- Straight 1/2" unions (pair)TT2961£9.30
(For use with screw in temperature adaptor and thermostat).

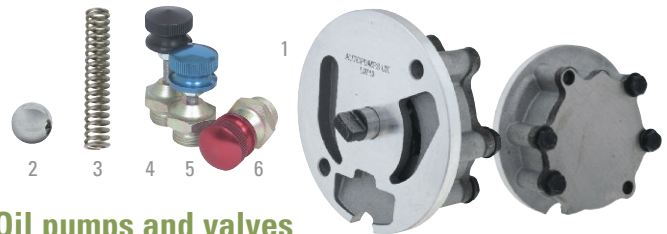

Oil pumps and valves

Good oil supply is a must, with the Mini's cornering capabilities oil starvation is a possibility all precautions should be taken. The oil pressure regulator allows you to adjust the preload on the oil pressure relief valve so you can alter the peak oil pressure. Please remember oil pumps require priming before fitment. Always remove spark plugs and spin engine over until oil pressure registers. See page A23 for K&N performance oil filters.

- 1 Oil pump turbo large capacityGLP110£37.96
- 2 Oil release stainless steel valve ball12H865X£1.98
(No sticking valves).
- 3 Oil valve spring (use with 12H865X)6K853C£1.43
- 4 Adjustable oil pressure valve - blackMT1112£15.60
- 5 Adjustable oil pressure valve - blueMT1113£15.60
- 6 Adjustable oil pressure valve - redMT1114£15.60



Oil catch tanks

A must for competition use to prevent oil spillage on the track. Manufactured from high grade aluminium and anodised for a smart, durable finish they feature 2 x 1/2" OD connectors for the breather hoses, level indicator, breather cap and drain plug. Available in 1 litre or 2 litre sizes. Mount using the rear flange to a suitable vertical panel in the engine bay.

- Oil catch tank 1ltTT2900£139.96
- Oil catch tank 2ltTT2901£155.95
- Breather hose - 1/2" ID (per metre)BAU5065M ...£10.20
- Hose clip (each)GHC11016 ...£1.70



Central oil pick up pipe

The standard oil pick up pipe is located to the RH side of the gearbox and oil surge during cornering can send the oil away from the pick up. This central oil pick up relocates the pick up point to the centre of the gearbox ensuring it is always submerged. Recommended if you are rebuilding the engine or gearbox.

CAHT54£29.00



Anodised dipstick

These are beautifully crafted dip sticks which use two rubber 'O' rings to secure them into the engine, with a choice of either a red or blue anodised knob.

Dipstick with anodised knob - blue
GAC8457X£10.15
Dipstick with anodised knob - red
GAC8458X£10.15



Magnetic oil trap

Designed to collect any metal particles at the top of the pick-up pipe, before they reach and destroy the oil pump. For all A series transverse engine and gearbox assemblies.

MS3313£18.35



Quick gear shift kits

Shorten the throw between gear changes... This kit improves feel and reduces gear lever travel resulting in a faster, slicker change. Available for either remote or rod type gearboxes, the kits include a modified gear lever, retainer and mounting hardware for simple installation.

Quick shift kit remote type
KAD1013218£63.95
Quick shift kit rod type
MRAC1751£40.80

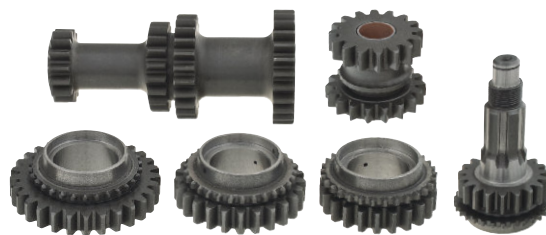

CAJJ4014

Straight cut gear kits

The original design Special Tuning gear ratio set is available in three versions. Remote type and two rod type gear kits A series and A+. A series main shaft has 14mm nose into 1st motion shaft and A+ has 18mm nose on main shaft.

Straight cut gear kit remote typeCAJJ4014 ...£510.95
Straight cut gear kit rod A+ typeCSTN77 ...£542.95

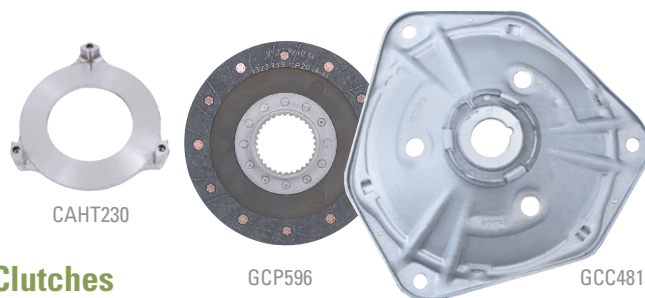

CAHT230

GCP596

GCC481

Clutches

The much sought after 22G270 'S' clutch back plate has been out of production for many years, but has now been replaced with CAHT230. It was liked because of its strength. Although not steel, it was cast in a very high grade iron, the exact same material used here. This item is cast fairly light 3.56.lbs (Std 5.7lb), but can be lightened further if required, call for details.

Clutch pressure plateCAHT230 ...£117.95
Clutch plate - road/rallyGCP596 ...£96.95
Clutch cover - road/rallyGCC481 ...£37.06
Clutch cover - rally/raceGCC482 ...£44.80



CAEG619

Lightweight steel flywheels

Using a lightweight steel flywheel has the same effect as lightening the car. Reducing the mass of rotating components in the engine helps the engine accelerate more easily leading to better acceleration of the car. These high quality steel flywheels are considerably lighter than the standard cast items and offer improved strength and a harder wearing clutch face. Their symmetrical design means they also reduce harmonic vibrations.

We offer flywheels in two specification; Roadlite and Racelite. Roadlite flywheels weigh in at 5kgs (11lbs), half the weight of a standard 1275cc. Our Racelite flywheels weigh in at just 3.63kgs (8lbs) for maximum weight saving in competition engines and are manufactured from EN8 grade steel.

Roadlite lightened flywheels

Diaphragm clutch with pre-engaged starterCAEG420 ...£149.95

Racelite lightened flywheels

Diaphragm clutch with inertia starterCAEG619 ...£155.95

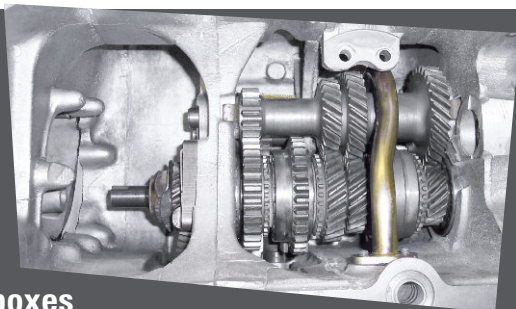

Gearboxes

These reconditioned gearboxes are available in either standard rod type or standard remote type. Both are subject to exchange.

Gearbox recon. standard rod type (exchange) ...MT2101 ...£490.94
Gearbox recon. standard remote type (exchange) .MT2102 ...£468.95





CAJJ3385

Cross pin differential units

With twice the standard number of cross pins and planet gears this differential can handle significantly more power without breaking and as an added bonus it has less tendency for torque steer.

EVO cross pin diff. unit (four planet gears)CAJJ3385 . . .£177.95
 Diff. pin competition strength for standard diffs. .C-BTA166 . . .£15.60

Crown wheel + pinions for standard or cross pin differentials

- 3.46:1 crown wheel + pinion 52 x 15 teeth*CBTA1001 . .£255.95
 - 3.76:1 crown wheel + pinion 64 x 17 teeth*CBTA1002 . .£255.95
 - 3.93:1 crown wheel + pinion 55 x 14 teeth*CBTA1003 . .£255.95
 - 4.07:1 crown wheel + pinion 53 x 13 teeth*CBTA1004 . .£255.95
 - 4.31:1 crown wheel + pinion 56 x 13 teeth*CBTA1005 . .£255.95
 - 4.57:1 crown wheel + pinion 64 x 14 teeth*CBTA1006 . .£255.95
 - 4.67:1 crown wheel + pinion 56 x 12 teeth*CBTA1007 . .£255.95
- (*Stronger semi helical cut teeth for standard or cross pin differentials).



CAJJ3387

CBTA1250

Limited slip differentials

Evolution LSD is an upgraded version of the popular Salisbury clutch type. It has improved clutch material and a unique design for smooth transitions between loaded and unloaded. Extremely easy and predictable to drive.

The first number is the deceleration ramp: 90 degrees deceleration ramp gives no drive. The second number is the acceleration ramp: 35 degrees acceleration ramp gives more drive, their round cross-section and matching curved ramps facilitates changes to the locking action on acceleration and deceleration of the differential.

- Limited slip differential - raceCAJJ3387 . .£520.94
- Limited slip differential 45/45 ramp - rallyCAJJ3387A . .£551.95
- Limited slip differential 90/50 ramp - roadCAJJ3387B . .£551.95

- Output shaft for pot joints (GCV1102)CBTA1263 . .£81.95
- Output shaft for Hardy Spicer joints (27H7880) .CBTA1262 . .£93.95
- Output shaft circlip (holds output shafts to diff.) .CCN122 . . .£1.48

Crown wheel + pinions for limited slip differentials

- 3.46:1 crown wheel + pinion 52 x 15 teeth*CBTA1250 . .£255.95
 - 3.76:1 crown wheel + pinion 64 x 17 teeth*CBTA1248 . .£255.95
 - 3.93:1 crown wheel + pinion 55 x 14 teeth*CBTA1252 . .£255.95
 - 4.07:1 crown wheel + pinion 53 x 13 teeth*CBTA1246 . .£255.95
 - 4.23:1 crown wheel + pinion 55 x 13 teeth*CBTA1251 . .£255.95
- (*Stronger semi helical cut teeth for limited slip differentials only).

High torque starter motor

These high torque starter motors offer increased torque and are a straight replacement for the original, however only weighs 3.9kg. The huge increase in cranking power is essential for engines with increased compression ratios.

- High torque starter motor inertia typeGXE4404X . .£187.94
- High torque starter motor pre-engaged type . . .GXE4527X . .£187.94

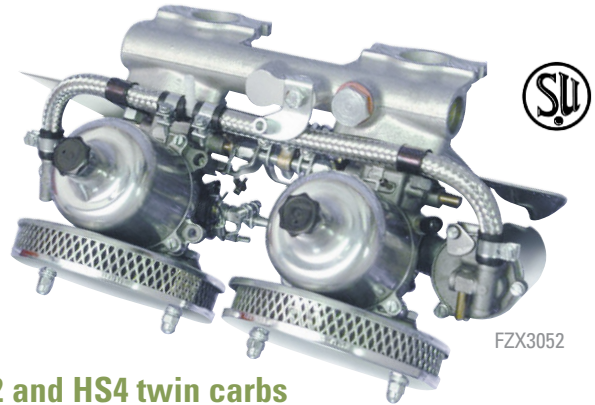

FZX3052

HS2 and HS4 twin carbs

Increase the power from your Mini with one of these kits. They are designed to allow more fuel and air into the engine, whilst keeping that distinctive period look of a pair of classic SU carburettors. For the best results these carburettors require a sports exhaust system (at least). The twin carburettor kits include all the parts you need to fit them including manifold, heat shields and carburettors. (Air filters not included).

- HS2 twin carburettor kitFZX3052 . .£712.96
- HS2 twin carburettors onlyAUD662T . .£536.95
- HS4 twin carburettor kitFZX3054 . .£752.95



Dashpot covers for SU carburettors

Polished or anodised dashpot covers are an easy way to brighten the engine bay.

- HS2 dashpot cover - silverSFR22£8.95
- HS4/6 dashpot cover - silverSFR23£8.95
- HS4/6 dashpot cover - anodised blueSFR23B . . .£8.95
- HS4/6 dashpot cover - anodised redSFR23R . . .£8.95
- HIF carburettor dashpot cover - silverSFR24£8.95

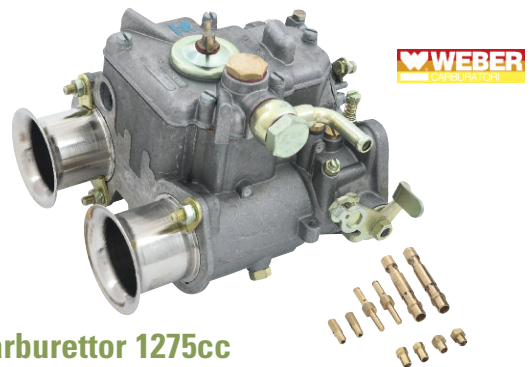

Weber carburettor 1275cc

This Weber carburettor is fitted with the basic jets and chokes that are correct for fast road applications, although these will still require fine tuning when on the car to receive maximum performance and economy.

- 40 DCOE Weber carburettor - fast roadTT29343308 .£459.95

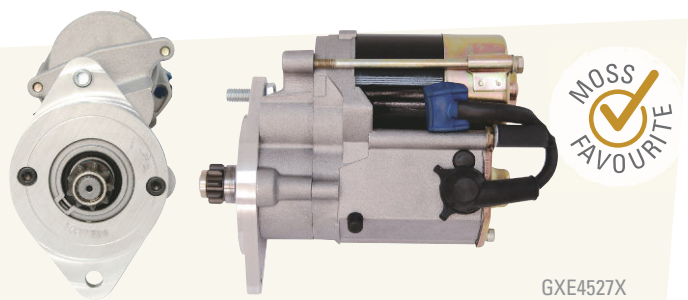

GXE4527X

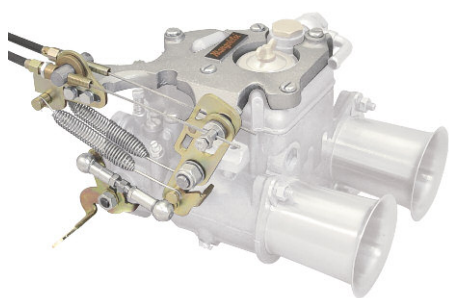

Carburettor not included

Weber DCOE throttle linkages - Mangoletsi

Mangoletsi is a long established name in the performance tuning industry, and a leading manufacturer of competition inlet manifolds & throttle linkages. We now offer Mangoletsi's new range of DCOE 'sliding set-up' throttle linkages.

This new simple design features a cast bracket which fits over the top of the carburettor, holding the linkage neatly to the side of the carburettor. This unique design has an ultra-low profile - the highest point of the linkage is only 10mm higher than the carburettor, ideal if clearance is limited. Each kit is suitable for single or twin carburettor set-ups for in-line engines.

The unique design also gives a wide range of throttle adjustment. Cable travel and spring tension can be adjusted independently. The adjuster can be set to give the desired cable travel, the spring tension can then be set to give the correct throttle shut off. This allows the throttle feel to be fine tuned to the driver's requirements.

- Throttle linkage DCOE - twin cableLP42451£93.95
- Throttle linkage DCOE - single cableLP42411£81.95

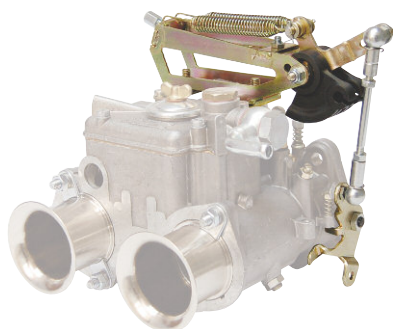

Carburettor not included

Weber DCOE throttle linkages - Webcon

Webcon linkages have been designed to offer a variety of fitting layouts to give flexibility of installation.

The lightweight construction is manufactured from steel and zinc-plated to match existing components on the carburettor, giving an OEM look.

Available in top or bottom mount for single or twin cables. Cables can be routed from either side and the linkage offers adjustment for cable movement from 22-40mm. The outer cable is retained in the adjuster whilst the inner cable fits to a quadrant cam, featuring sintered bronze bearings, giving a smooth linear action. High quality 8mm ball joints, with an opposed threaded rod, are used on the linkage for ease of adjustment and set up.

Single cable kits use the existing throttle cable whilst the twin cable kits include a pair of nylon lined cables and an adaptor block to convert the throttle pedal.

- T/linkage DCOE - top mount/single cableLP4100£96.95
- T/linkage DCOE - top mount/twin cableLP4101£102.95
- T/linkage DCOE - bottom mount/single cable .LP4102£96.95
- T/linkage DCOE - bottom mount/twin cable .LP4103£102.95

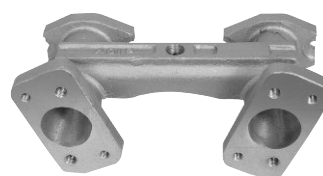

Twin SU alloy inlet manifold

This intake manifold is for twin SU's (HS2 or HS4).

- Twin SU alloy inlet manifoldLP4012£149.95



C-AEG489

Twin SU alloy inlet manifold

This intake manifold is for twin SU's (HS4 or HS6) produced to the original Abingdon ST design. The throttle bracket is suitable for twin SU manifolds.

- Twin SU alloy inlet manifoldC-AEG489 ...£67.96
- Twin SU throttle bracketAEG349£5.80
- Screw for throttle bracketSH504041£0.25

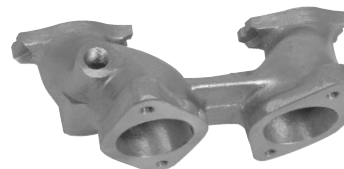

Weber inlet manifolds

Single Weber/Dellorto inlet manifold 10cm (4 inch) long. This manifold will require bulkhead modifications.

- Single Weber/Dellorto 10cm inlet manifoldTT10850 ...£140.95

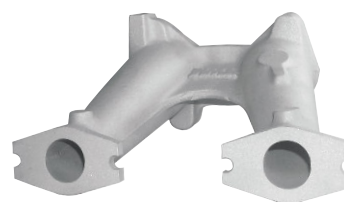

Single Weber/Dellorto inlet manifold 15cm (6 inch) long. Supplied complete with direct acting throttle linkage. Will require bulkhead modifications.

- Single Weber/Dellorto 15cm inlet manifoldTWM0071 ..£308.95

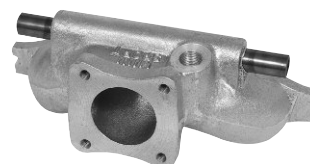

High flow alloy inlet manifold

High flow alloy inlet for 1.75" carburettors, the larger ports make this manifold ideal for large capacity engines e.g. 1380cc.

- High flow alloy inlet manifoldMT3603£52.96
- Blanking plug (if brake servo not used)ADP210£4.96
- Sealing washerAED172£0.86



**Million Mile
LIMITED WARRANTY**

K&N Filters

Renowned as being one of the most efficient air filtration systems available.

KN56-1630A



Their reinforced cotton weave is impregnated with a specially formulated oil to retain airborne particles. Offering much improved air-flow over standard paper elements, they are essential for fast road and competition applications.

Available for most models, see page A23 for Classic Mini filters.



KN56-9105

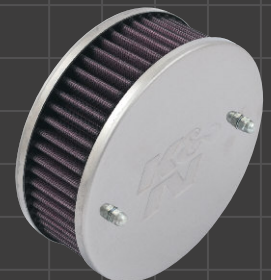

KN56-9096



KN56-9327



KN60-1280

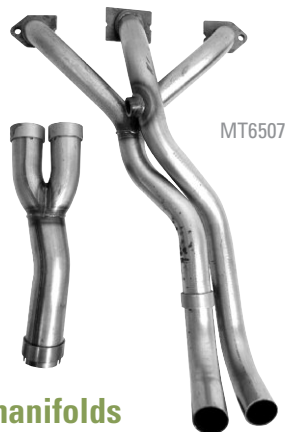

Pro Flo LCB manifolds

New to the market, these well designed Pro Flo manifolds feature a larger secondary pipe than usual. Perfect for performance tuning on fast road cars.

- Pro Flo exhaust manifold injection modelsMT6507£61.96
- Pro Flo exhaust manifold carburettor modelsMT6508£69.95
- Blanking plug for lambda sensor (as required)WPE1104X£3.46



LCB manifolds

The medium bore long centre branch manifold (LCB) is probably the most popular for the Mini in production today. Suitable for engines up to 1380cc this is the first step to greater performance. This Manifold long centre branch exhaust manifold is for applications up to 100bhp and includes primary pipes and Y piece with clamps.

- LCB mild steel manifold (carbs. to 100bhp)GAC8463X£84.95
- LCB mild steel manifold (injection with cat.)MT6505£132.95
- Blanking plug for lambda sensor (as required)WPE1104X£3.46
- LCB exhaust manifold Y piece (as required)GAC84631£79.96



Freeflow manifold

This freeflow exhaust manifold is specifically manufactured in mild steel for the Cooper model.

- Freeflow mild steel manifoldMT6101£79.96

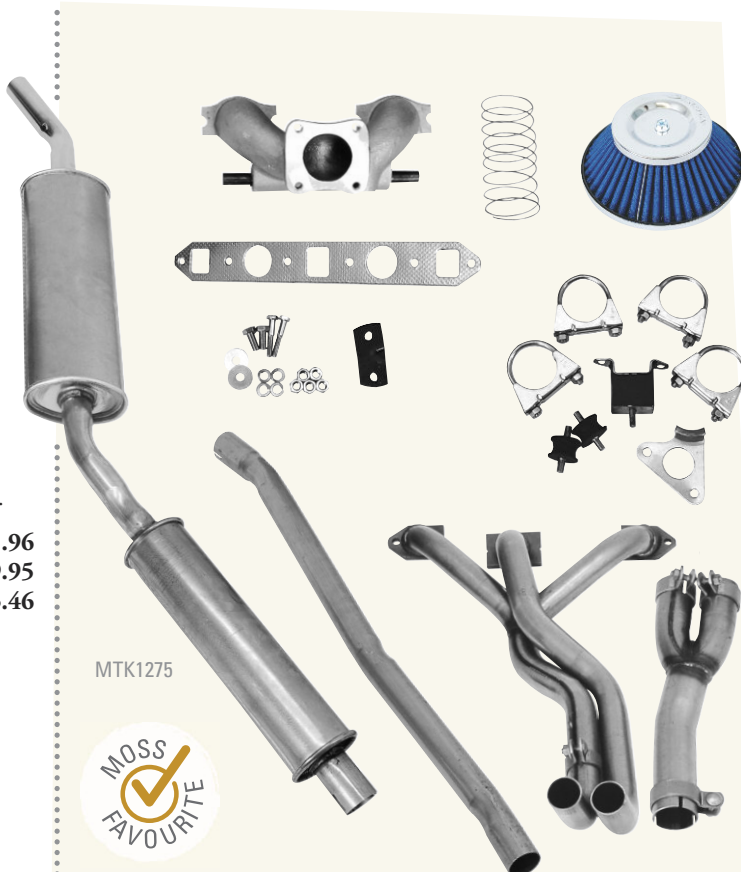

MTK1275



Stage one tuning kits

Our stage one tuning kits are available for both the 998cc & 1275cc carburettor Classic Mini models. When developing the tuning kits, only tried and tested high quality components that would actually improve the Mini's performance were selected.

For example; the Moss kit uses the legendary RC40 exhaust system which not only adds bhp but also produces a satisfying sporty tone, while remaining suitable for all types of driving.

These comprehensive kits contain everything required for fitting to a standard car, including a new needle and spring for the carburettor.

- Stage one tuning kit (998, 1071, 1098cc)MTK998£207.95
- Stage one tuning kit (1275cc)MTK1275£229.96



MT6506

Performance exhaust manifold

This highly polished stainless steel manifold is designed to work with our range of Fletcher performance exhausts, page A18. Made from 304 stainless the finish and the welding on this product is just about as good as it gets.

- LCB stainless steel non-catalyst modelsMT6506£132.95
- Blanking plug for lambda sensor (as required)WPE1104X£3.46





Exhaust heat insulation

Wrapping a tubular manifold will keep engine bay heat to a minimum, reducing engine bay temperatures by up to 70%. This will benefit power in two ways; firstly it will reduce the temperature of the air going into the engine; secondly, it improves the effectiveness of the manifold by increasing gas speed due to lower gas density, increasing the scavenging effect.

This race proven, asbestos free, product from Thermo-Tec is manufactured from Silica based yarns and is unaffected by oil or water, whilst withstand temperatures of up to 1000°C. As a guide to coverage a 2" x 50' roll will cover approximately 13ft of 2" pipe. Manifold wrap is supplied in a variety of sizes, see below for details. Use Snap Straps to hold the wrap in position.

Roll size (W x L)	Natural	Black
1" x 15' roll	.GAC150£11.95	GAC151£13.94
2" x 15' roll	.GAC152£19.94	GAC153£21.95
1" x 50' roll	.GAC154£34.96	GAC155£38.95
2" x 50' roll	.GAC156£58.96	GAC157£64.96

Manifold blanket

Using a manifold blanket provides excellent heat retention for exhaust manifolds and can be easily installed to both cast iron and tubular manifold. Manifold blanket should be retained with Snap Straps.

Manifold blanket 4-6 cylinder	.GAC182£99.95
Manifold blanket V8 2 piece	.GAC183£108.95

Snap Straps

Use Snap Straps to hold the wrap or blanket in position.

Snap Strap kit 8 x 9" & 4 x 18" lengths	.GAC172£31.94
Snap Strap kit 6 x 9" & 4 x 18" lengths	.GAC173£27.95
Snap Strap kit 12 x 9" lengths	.GAC174£29.95
Snap Strap kit 6 x 18" lengths	.GAC175£19.94
Snap Strap kit 4 x 14" lengths	.GAC176£9.95

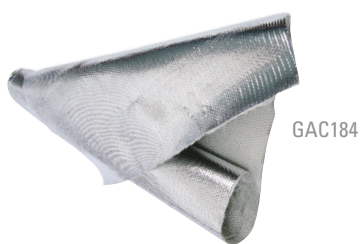

Heat shield

Radiant heat coming through the floors and bulkhead can make the cockpit of your Mini a hot place to be. Insulating the floors and bulkhead not only keeps the heat out but it can also prevent damage to carpets, paintwork and interior fittings where exhaust pipes, silencers and catalytic converters are in close proximity to the panelwork.

Exhaust heat shield can be used on the underside of the floors where the exhaust runs close to the floor particularly above silencers and catalytic converters. It effectively reflects 90% of the radiant heat from exhausts and can withstand temperatures up to 1000°C. The general purpose material can be used to cover bulkheads and floors to keep general heat transfer to the cockpit to a minimum. It can also be used to wrap and cover components in the engine bay to prevent heat damage.

Exhaust heat shield 40" x 24"	.GAC184£78.95
General heat shield 1m x 1m	.GAC185£71.95
High temperature adhesive	.GAC9908X£8.95



Twin SU stainless steel heat shields

These new mirror finish stainless steel heat shields not only look great they also redirect some of the heat from the exhaust manifold.

Twin SU stainless steel heat shields for HS2	...MST018£16.96
Twin SU stainless steel heat shields for HS4/6	...MST019£16.96

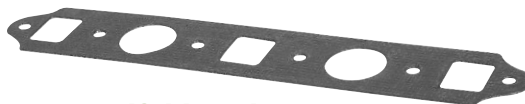

Large port manifold gasket

The large ports on this gasket allow fitment of performance manifolds with larger primary pipes.

Manifold to cylinder head gasketTMG10836£3.95
----------------------------------	---------------	------------

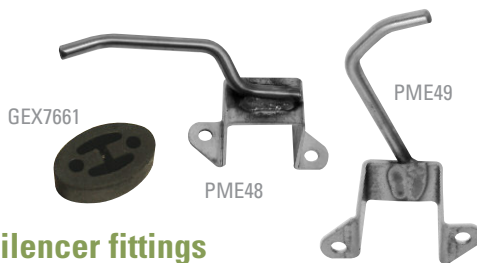

Rear silencer fittings

Early Minis used rubber blocks to hang the original exhausts from. The Play Mini range uses the later type of hook brackets and rubber hangers. These fitting kits contain all components, including the hanger conversion brackets, to allow easy installation. Simply use hanging rubbers for late cars.

Fitting kit side exitWPE3003X£39.95
Fitting kit centre exitWPE3002X£25.96
Subframe hanger bracket frontPME48£14.20
Subframe hanger bracket rearPME49£14.10
Hanging rubberGEX7661£3.95
Catalytic converter gasketGEX7761£1.50

PLAY MINI The Magic Pipe... designed to fit to the original cast manifold but will enable you to fit most of our systems to your Classic Mini.

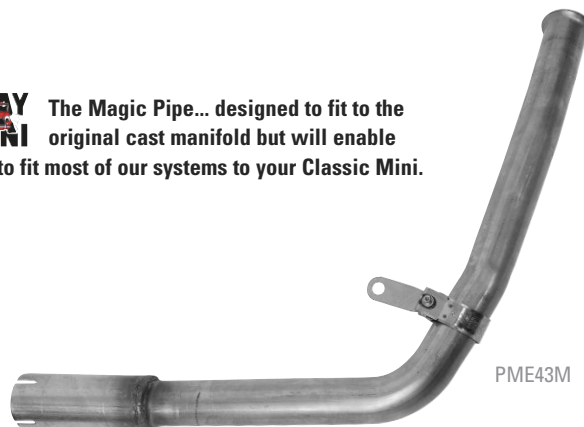

Play Mini stainless steel - magic pipe

For those of you who don't want to fit an LCB manifold to the car this pipe is designed to fit to the original cast manifold but will enable you to fit most of our systems to your car. Please note this pipe is for carb models only.

Down pipe - magic pipePME43M£46.96
Manifold clampGEX7046£2.24
Exhaust clamp 2"GEX9009£0.90

RC40 and RC50 exhaust systems

The RC40 and the stainless steel version, the RC50, are renowned as 'the systems' to have when improving the Mini performance. With tuned silencer boxes, and computer optimised tube lengths the system can release more power when combined with the LCB manifold.

We also stock just the rear RC40 silencer fitted with a pipe to bolt straight on to the catalyst for cars built late 1991-on SPI & MPi (not early carb coopers). The intermediate pipes are the correct length and shape to fit directly to the Cooper Freeflow exhaust manifold but will require a short length of the front part of the pipe to be cut off to fit an LCB exhaust manifold.

RC40 and RC50 Exhaust Systems - Carburettor Models without Catalyst

(All kits include intermediate pipe).

- RC40 system, side exit single box, mild steelGEX40RCS . . .£45.95
- RC40 system, side exit twin box, mild steelGEX40RC . . .£59.95
- RC50 system, side exit twin box, stainless steel . .GEX50RC . . .£212.95
- RC40 system, centre exit single box, mild steel . .GEX40RCC . .£71.50
- RC50 system, centre exit single box, stainless steel .GEX50RCC .£216.95
- RC40 early type exhaust fitting kitGEX40FK . . .£10.50

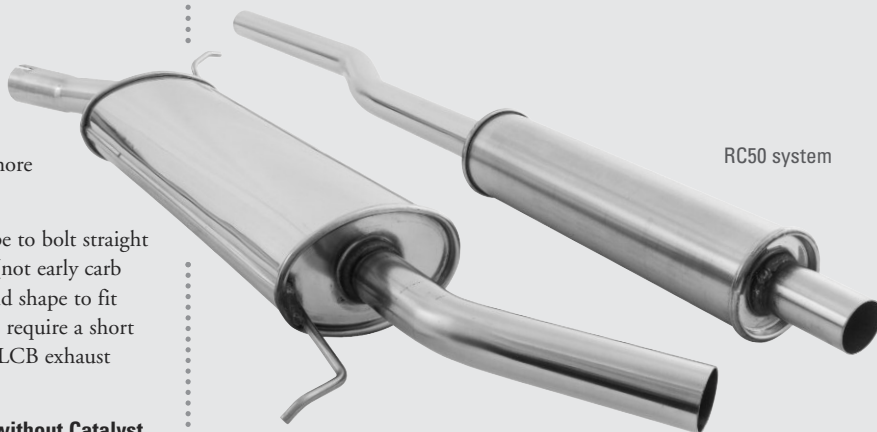

RC50 system

RC40 Exhaust Systems - Carburettor and Injection Catalyst Models (1991-On)*

(*Not early Cooper carb models).

- Silencer Assembly, RC40, catalyst back, mild steel .C-STR811 . . .£87.95
- Silencer Assembly, RC40, catalyst back, stainless steel .C-STR811S .£143.95
- Catalyst gasketGEX7761£1.50
- Exhaust hanger, rubberGEX7661£3.95

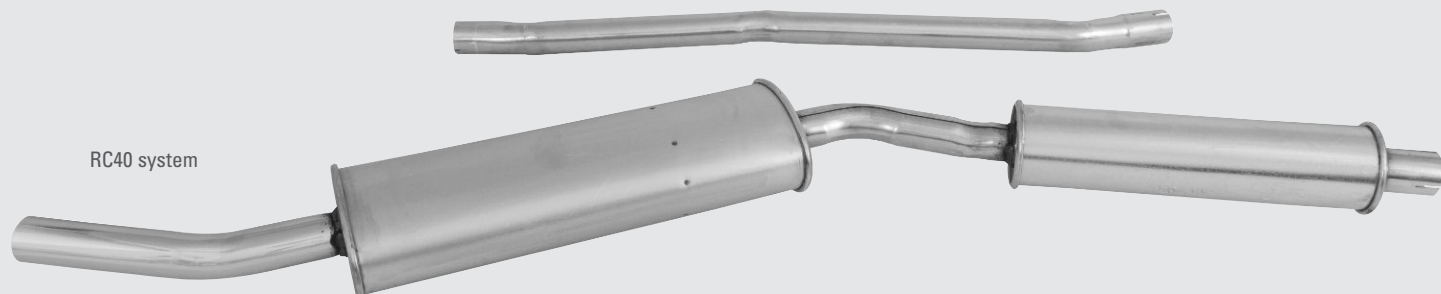

RC40 system

The RC40 and the stainless steel version, the RC50, are renowned as 'THE SYSTEMS'...

Stepped adaptor

This useful adaptor allows the fitting of any back box to a standard system. Simply cut the existing system where appropriate.

- Stepped adaptor 1.25" to 2"PME43X . . .£17.15



Mikalor exhaust clamps

These high quality stainless steel clamps are ideal for use on your Mini exhaust. The strap design and clamp mechanism ensure that even clamping pressure is applied all round the joint.

- Mikalor clamp 1 1/2" (37-40mm)TT9930S . . .£2.26
- Mikalor clamp 1 5/8" (40-43mm)TT9931S . . .£2.45
- Mikalor clamp 1 3/4" (43-47mm)TT9932S . . .£2.95
- Mikalor clamp 1 7/8" (47-51mm)TT9933S . . .£2.45
- Mikalor clamp 2" (51-55mm)TT9934S . . .£2.45
- Mikalor clamp 2 1/4" (55-59mm)TT9936S . . .£2.65
- Mikalor clamp 2 1/2" (63-68mm)TT9938S . . .£2.84

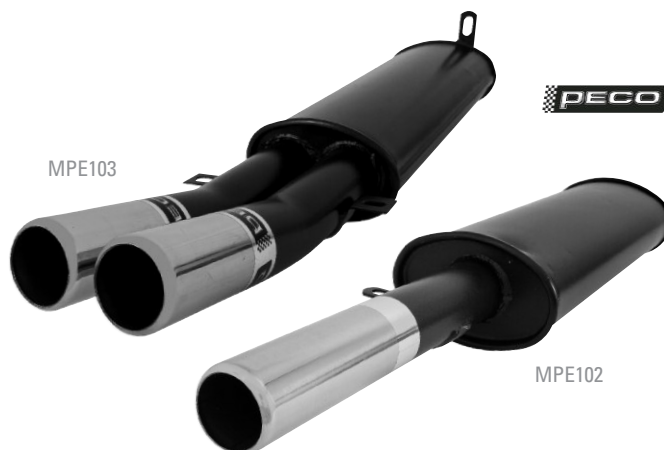

MPE103

MPE102

Peco performance exhaust silencers

A popular accessory for any performance Mini is the Peco rear silencer with twin upswept tail pipes. Available for non catalytic converter cars 998cc or 1275cc models.

- Peco single upswept tail pipe (998cc only)MPE101 . . .£104.95
- Peco single straight tail pipe (998cc only)MPE102 . . .£97.96
- Peco twin upswept tail pipes (998cc only)MPE103 . . .£132.95
- Peco single upswept tail pipe (1275cc only)MPE105 . . .£104.95
- Peco twin upswept tail pipes (1275cc only)MPE107 . . .£127.96



Performance exhausts



Many Classic Mini owners like the rumble from a performance exhaust system. There are many options available and it can be confusing trying to work out what piece fits with what...

To help with the selection of our performance exhaust systems, we have added these simple layouts for carburettor and injection models to make things a little clearer. It's as easy as 1, 2, 3, (4, 5)... The layout starts at the front of the car with the manifold working its way back.

The selected exhaust system pieces shown here are known to fit together so that you can choose the pieces you want and avoid any problems with fitment.

If you're still unsure about what you need please call us and we will be happy to help.



Carburettor models without Catalyst

LCB manifolds

1

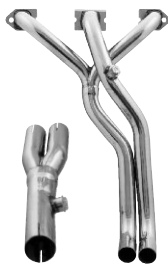

LCB stainless steel manifold
MT6506£132.95

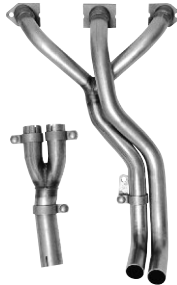

Pro Flo LCB mild steel manifold
MT6508£69.95

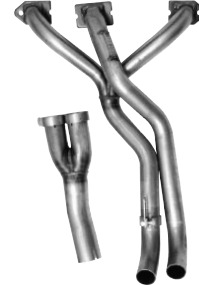

LCB mild steel manifold
GAC8463X£84.95

Link pipes

2

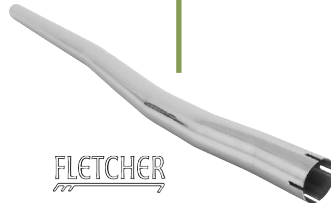

Fletcher universal link pipe
FES100£41.05

Rear silencers

3



Fletcher side exit single pipe
FES200£129.95



Fletcher DTM centre exit pipe
FES201£159.95



Play Mini centre exit single pipe
PME41£135.95



Play Mini centre exit twin pipe
PME42£151.96

Injection models with Catalyst

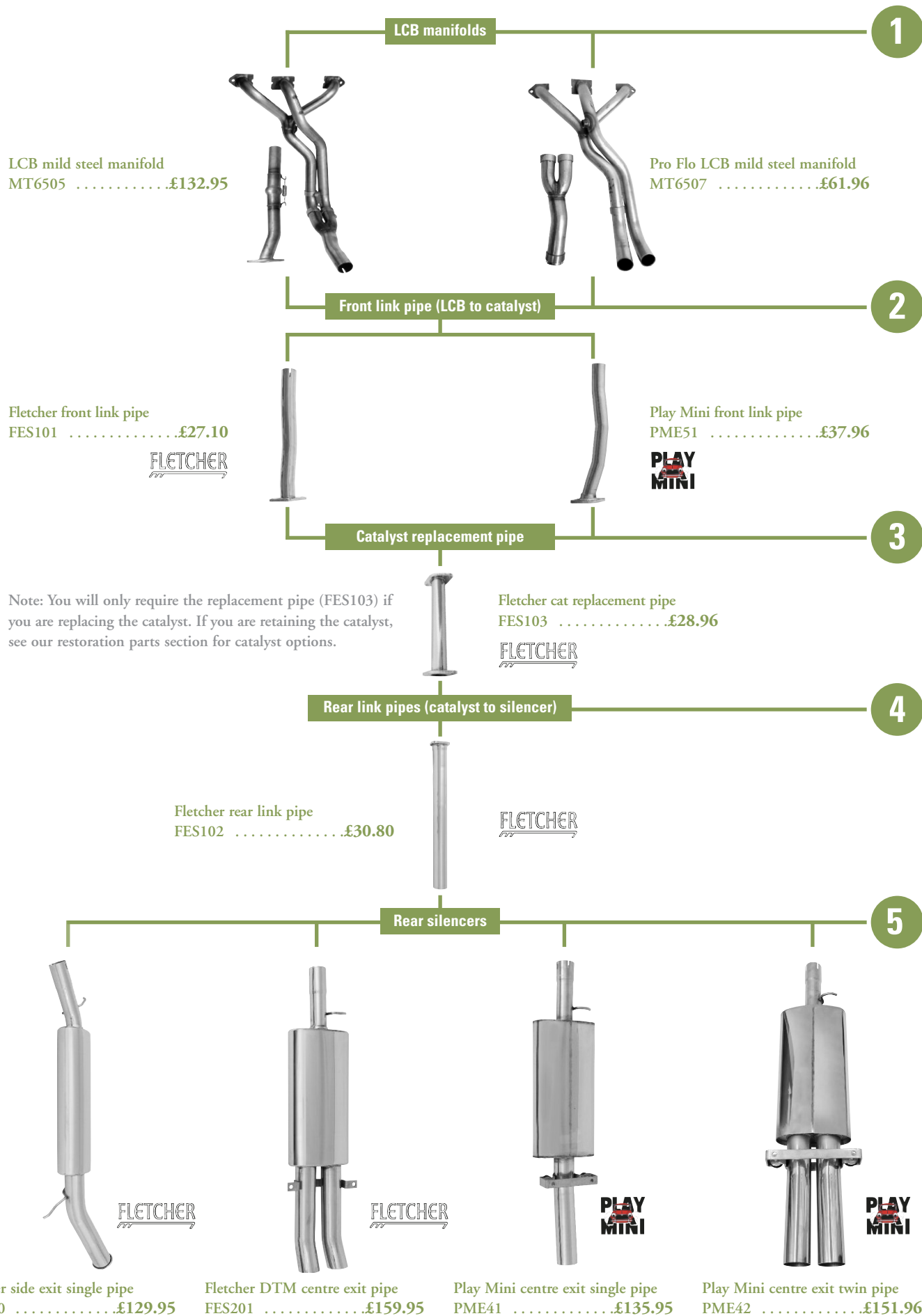



Coil clamp & cover

Brighten up your engine bay with our stainless steel coil clamp and covers for standard coils only. Coil not included.

- Stainless steel coil clamp onlyGAC8470X£7.25
- Stainless steel coil clamp & coil cover setGAC8470CC .£11.20

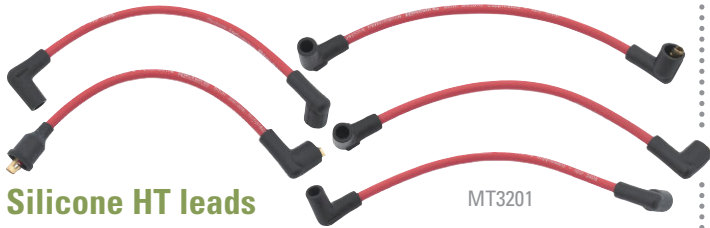

Silicone HT leads

These HT lead sets are made from high quality silicone. Offering high conductor performance with awesome looks.

- Performance HT leads 8mm - blueMT3200£13.94
- Performance HT leads 8mm - redMT3201£13.94
- Performance HT leads 8mm - yellowMT3203£15.76



Cobalt performance HT lead sets

Get the spark from your coil with silicone HT leads that are designed to perform. These Cobalt leads use a high performance conductor to transmit greater energy to the spark plug creating a stronger spark for improved combustion. They also feature multi-layer reinforcing and insulation with protective silicone outer sleeve and terminal boots for improved reliability. Engines with a Lucas 25D distributor require a top entry 'push in' type distributor cap GDC103.

- Cobalt silicone lead set (848-1275cc)TMG10872 . .£33.95
- Top entry push in distributor cap (848-1275cc) . .GDC103£4.20



NGK spark plugs and plug caps

Changing the spark plugs regularly ensures the engine performs well. NGK are renowned for making performance plugs giving a strong spark and long life.

- 1 Spark plug (all eng. cc) - standard tuneBP6ES£3.25
- 2 Resistor spark plug (all eng. cc) - standard tune .BPR6ES£4.90 (For radio suppression).
- 3 Spark plug - tuned roadBP7ES£3.55
Spark plug gold palladium electrode - tuned road .BPR7EIX . . .£12.20
- 5 Straight plug cap (each)NSB5£3.10
- 6 60° plug cap (each)NYB5£3.10
- 90° degree plug cap (each)NLB5£3.35
- 8 Push-in connector distributor cap & coil (each) GCL1110£1.25



Sports coils

Sports coils are designed to improve ignition performance. They give more reliable starting power and greater performance at high revs thanks to the 40,000 volt output. Don't forget to renew your plugs and leads to optimise the power. Only use the ballast type coil if your car is fitted with a ballast resistor in the wiring. Please check before ordering. Your HT lead into the coil will need to be the push-in type, use GCL1110 to convert the lead.

- Sports coil non-ballast typeTT2981£22.94
- Sports coil ballast typeTT29812£27.95
- Ignition lead end kitGCL1110£1.25



Bumble bee competition HT lead

If you want a performance HT lead with the correct period look then this 'bumblebee' lead is a must. As per the original 'Lucas' type it features a high conductivity copper core with a yellow insulator featuring a black stripe. Alternatively, use the standard black lead for an 'OE' look. We recommend you assemble leads with NGK suppressed plug caps.

- Bumblebee HT lead (per metre)TT2982M£7.25
- HT lead (per metre) - blackAAA5981M . . .£2.76



HT lead numbering set

Keep track of which HT lead is which with a set of four numbered sleeves.

- HT lead numbering set 4 cylinderCRST255£3.95



Electronic distributor

This electronic distributor was originally fitted to all standard Cooper 1275cc carb models. It can also be used on any A+ 1275cc car using a carburettor! No points or condenser to worry about either. Also available is the plug & lead to connect to the existing wiring.

- Electronic distributor & lead kit 1275ccAUU1536K . .£105.95
- Electronic distributor 1275cc (carb models)AUU1536 . .£112.96
- Plug & lead54966877£6.25
- CapGDC156£3.95
- Rotor armGRA2143£3.85



...designed for serious cooling



OEM QUALITY FANS

Revotec OEM quality fan assemblies are designed for serious cooling. Available in various diameters from 167 to 385mm or as part of a bespoke kit, designed for specific models. These fans are a great way to control the temperature of your car's engine.

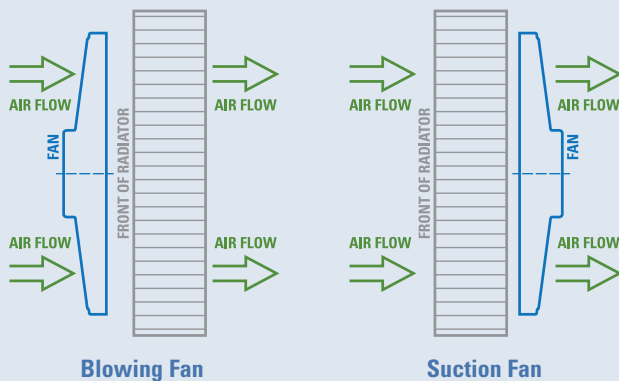

- High performance
- OEM quality
- Full bearing motors
- Low noise
- Light weight
- Versatile installation
- Low profile
- Finger guard

FAN ASSEMBLIES

Keeping your engine running at optimum temperature will ensure you get the best performance and economy. Revotec fan assemblies are designed to run continuously with no loss of performance or reliability. The high quality motor features bearings rather than bushes; the cases are fully waterproof with finger guards for safety.

UNIVERSAL FANS

Available in a choice of either suction (mounted behind radiator) or blowing (mounted in front of radiator), with a range of fan sizes, and either a slim-line or high power motor specification. The fans can be mounted in a variety of ways. Universal brackets are available to suit the various fan sizes and can be adapted to suit the application. We recommend installing the fan with a Revotec electronic temperature controller.

BESPOKE FAN KITS

Revotec and Moss Europe have co-designed high quality bespoke fan kits for Classic Mini, MG, Triumph and Morris Minor models. Designed specifically to fit each model fitting is quick and straight forward with no permanent modifications.

Using the latest high efficiency fans with adjustable electronic controllers these kits are designed to replace the standard original mechanical fan, reducing the load on the engine, noise and improving both power and mpg.

Unlike other fan kits that use a universal mounting system, these Revotec kits have bespoke laser cut brackets that mount directly to the radiator mountings. The brackets are bright passivated to give a smart appearance and prevent corrosion. The kits also use a precise electronic controller to enable easy adjustment to suit your car.



Model: MGA
Part no. RFK56

The model kits include:

- High efficiency fan assembly
- Electronic controller with special top hose
- Bespoke passivated brackets for corrosion resistance
- Hardware & wiring Fitting instructions

SEE PAGE A09 FOR A BESPOKE REVOTEC KIT FOR YOUR CLASSIC MINI



Lumenition ignition

Lumenition electronic ignition kits are well known as being among the finest after-market electronic ignition systems available. This system basically replaces both the contact points and condenser with an optical switch and power module. The power module is an electronic device that receives a pulse from the optical trigger which switches the coil. The trigger eliminates contact bounce, arcing, mechanical wear and spark scatter, reducing maintenance and increasing reliability. With minimal wiring and modifications this kit is very discreet. **Note: Installation of a power module requires a distributor fitting kit.**

A performance ignition kit is available, it includes a power module and a high output coil. The microcircuit control of the coil current gives optimum performance across high engine speed ensuring maximum spark energy at the coil. A fitting kit, to suit the distributor application, is also required. Positive earth wiring instructions are available from your branch. Please check your distributor type before ordering the fitting kit as many cars have non-original distributors fitted. The identification number is cast on the distributor body.

Performance ignition kit

Supplied with high energy coil and performance power module. Requires fitting kit to suit distributor.

- Performance ignition kitCEK150£254.95
- Coil replacement for CEK150CEC£59.95

Power module and performance ignition coil

- Power modulePMA50£175.96
- Performance ignition coil MegaSpark 4LMS4£41.70

Mounting bracket and fitting kits

Designed to mount the power module neatly using coil bracket screws. Use these fitting kits with your choice of ignition kit.

- Power module mounting bracket (all modules) . .MK006£10.15
- Lucas 22D4 25D4 distributorsLFK116£15.95
- Lucas 43/45D4 distributorsLFK117£15.95
- Lucas 45DE4 electronic distributorsLFK109£15.95
- Lucas 59D distributorsLFK117£15.95



Pertronix ignition

These self contained electronic ignition units offer a simple alternative to traditional points and condenser arrangement. Easily installed with no external control boxes to mount and only two wires to hook up and no permanent modifications involved. The unit uses a sealed Hall Effect sensor that is impervious to dirt, dust, moisture, or vibration and retains standard advance curve. Unaffected by distributor shaft wear, maintains firing accuracy to within 1/4°, reduces spark scatter over the rpm range. One year warranty.

- Pertronix ignition Lucas 23-24-25D4222-405£99.95
- Pertronix ignition Lucas 45D4222-435£99.95



CSI-Ignition distributors

CSI-Ignition distributors offer a fully electronic ignition system built into the correct type of Lucas distributor housing to suit your car, keeping the original appearance in the engine bay. You can only tell the difference when you remove the distributor cap!

Gone are the points and condenser and mechanical advance mechanism, all replaced with a high quality electronic ignition system manufactured using military specification components for durability and reliability. These distributors are maintenance free (no points to adjust), and offer the benefits of, easier starting & smoother running, more torque & power, reduced fuel consumption & emissions. They also eliminate the weaknesses of mechanical timing advance and problems such as points bounce ensuring correct ignition timing throughout the rev range.

“The new range of CSI-Ignition distributors is a breakthrough for classic car ignition systems”.

Each CSI-Ignition distributor features 16 easily switchable, optimised ignition curves to allow timing adjustment to suit your car’s engine and fuel specifications. Alternative advance curves can be selected to suit your engine’s state of tune making them ideal for modified engines. Curves are easily selected using a screwdriver in a rotary switch, with a bright flashing LED indicator to show the selected curve all concealed underneath the distributor cap. The distributors are also available with an electronic immobiliser system to prevent unwanted starting of the engine.

We offer a wide range of CSI-Ignition distributors for a variety of applications. They are available Optimised with vacuum advance to suit road or uprated cars running on SU carburettors, or tuned without vacuum advance for cars running Weber type carburettors. Please note: Some units may only be available to order. More details are available on our website, search for CSI-Ignition Distributor.

- Distributors for pre A+ engines - 850cc-1275cc, inc. Coopers (Lucas 25D)**
- Optimised 25D4 positive earthCSD8014571 £250.96
 - Tuned 23D4 positive earthCSD8023571 £250.96
 - Optimised 25D4 negative earthCSD8014581 £250.96
 - Tuned 23D4 negative earthCSD8023581 £250.96
 - Optimised with immobiliser 25D4 positive earth .CSD8014671 £373.96
 - Tuned with immobiliser 23D4 positive earth . . .CSD8023671 £373.96
 - Optimised with immobiliser 25D4 negative earth .CSD8014681 £373.96
 - Tuned with immobiliser 23D4 negative earth . . .CSD8023681 £373.96

- Distributors Pre A+ engines - 850cc-1275cc (Lucas 45D)**
- Optimised 45D4CSD8014582 £250.96
 - Tuned 43D4CSD8023582 £250.96
 - Optimised with immobiliser 45D4CSD8014682 £373.96
 - Tuned with immobiliser 43D4CSD8023682 £373.96

- Distributors A+ engines - 850cc-1275cc (Lucas 59D)**
- Optimised 59D4CSD8014583 £250.96
 - Tuned 59D4CSD8023583 £250.96
 - Optimised with immobiliser 59D4CSD8014683 £373.96
 - Tuned with immobiliser 59D4CSD8023683 £373.96

CSI distributors require a coil with minimum resistance of 2.5 ohms. We recommend our sports coil TT2981 3 ohms. Bypass the ballast resistor if fitted.

Sport coil (3 ohms)TT2981£22.94



Breather filters



Performance engine breather filters are an alternative to running pipes from the clutch housing and timing cover breathers. Short stack filters are available in three colours and simply push onto the breather. Just remember to block off the other on the carb or air filter end where the original pipe was attached.

- 1 Breather filter 12mm inlet - blueMT1200£6.76
- 2 Breather filter 12mm inlet - chromeMT1201£6.76
- 3 Breather filter 12mm inlet - redMT1202£6.76

K&N breather filters

- 4 Engine inlet breather filterKN62-1010 . . . £21.46
- 5 Crank breather filterKN62-1330 . . . £19.96



K&N performance filters (air & oil)



K&N air filters are probably the most efficient way of ensuring clean, dirt free air for the engine without compromising performance. We supply a tapered filter to fit as a replacement to the standard filter and case assembly within the confines of the engine bay. For those who wish to have the increase in cleaning and air flow efficiency without the increased noise, we offer a replacement filter element to fit directly into the standard filter casing.

- Twin HS2 pancake filter (850-1275cc to 1974) . .KN56-1630A .£87.95
- Twin HS4 K&N filter assemblyKN56-9128 . .£79.96
- Tapered HS4 K&N filter (1000cc)KN56-9320 . .£79.96
- Tapered HIF44 K&N filter (Cooper 1300cc) . . .KN56-9330 . .£71.95
- Tapered HS6 K&N filterKN56-9327 . .£84.95



K&N air filters (180mm x 120mm) for Weber carburettors

- DCOE fitting 45mm (1 3/4") deepKN56-1270 . .£79.96
(Not suitable for ram pipes).
- DCOE fitting 45mm (1 3/4") deepKN56-9106 . .£84.95
- DCOE fitting 63mm (2 1/2") deepKN56-9104 . .£87.95
- DCOE fitting 83mm (3 1/4") deepKN56-9265 . .£84.95



K&N air filter kit

- SPI performance filter kitKN57-0082 . .£84.95
(Complete with cold air ducting kit).



KNE9172

K&N replacement elements

- HS4 & HIF38 replacement element* (non inj.) . .KNE2601 . . . £34.96
 - SPI & MPI replacement element* (injection) . .KNE9172 . . . £34.96
- (*Fits into standard case).



K&N Performance Gold® oil filter

These K&N oil filters feature a number of improvements over standard oil filters, like higher flow rates, improved filtration, anti-drain valve and a nut for ease of removal. Originally developed by K&N for race applications these high quality filters are becoming a favourite among consumers who want only the best products for their cars. See page A10 for uprated oil pump.

- K&N Performance Gold® oil filter (A series) . . .235-830 . . . £10.96



Cone air filters

MT3210

MT3211

Performance cone air filters help improve the air flow to the carburettor. This type of air filter can be taken off, cleaned, re-oiled then put back on time and time again. Well made and looks great with the chrome finish.

- Cone air filter HIF44MT3210 . . . £39.80
- Cone air filter HS4MT3211 . . . £32.65



Ram pipes Ram pipes for Weber and Dellorto carbs

These ram pipes are designed to improve air flow into the Weber and Dellorto carburettors, ideal for use with or without filters, space permitting.

- 1 40 DCOE/DHLA 16mm ram pipeKNSS1640 . .£27.95
- 2 40 DCOE/DHLA 26mm ram pipeKNSS2640 . .£27.95
- 3 40 DCOE/DHLA 39mm ram pipeKNSS3940 . .£27.95
- 45 DCOE/DHLA 16mm ram pipeKNSS1645 . .£27.95
- 4 45 DCOE/DHLA 26mm ram pipeKNSS2645 . .£27.95
- 45 DCOE/DHLA 39mm ram pipeKNSS3945 . .£27.95



Ram pipes for SU carburettors

These fully radiused ram pipes improve air flow into the SU carburettor, ideal for use with or without filters (space permitting). The K&N ram stack is designed for their own filter assemblies.

- 5 HS4 K&N ram pipe - silverKN85-5039 . .£13.50
- HS2 ram pipe - silverSFR230 . . . £24.46
- 6 HS4 ram pipe - silverSFR430 . . . £24.46
- 7 HS6 ram pipe - silverSFR650 . . . £24.46
- 8 HIF4/44 ram pipe - silverSFR4430 . . . £24.46









Performance Polyurethane Bushes for Road & Track

Superpro high quality bushes offer better suspension location but without the added noise given by harder materials. Polyurethane bushes are easily fitted requiring no alterations, they are oil resistant and will not perish like rubber bushes.

Available in complete car and running gear sets as well as selected bushes. Replacing your car rubber suspension bushes with SuperPro poly suspension bushes will give you:

-  **Better road holding**
-  **Constant steering geometry**
-  **Increased tyre life**
-  **More responsive steering**
-  **Longer service life of suspension components**





Fuel pump inertia switch kit

This inertia switch is a good safety feature when using an electric fuel pump. The unit mounts to a vertical surface in the engine bay and in the unfortunate event of a crash cuts the power to the fuel pump preventing fuel spillage. Supplied with multi connector and tail leads to allow easy connections.

Fuel pump inertia switch kitC41220AX . . .£45.20

Battery cut-off switches

Battery cut-off switches are a good idea for all cars. Fitting one enables you to quickly isolate the battery and immobilise the car; ideal when working on your car, or if you intend to put your car into storage. Use with a battery conditioner, see our website or our Restoration Tools catalogue.



Battery mounted cut-off switches

These cut-off switches simply mount to the battery post and feature a screw-in knob to break the circuit. Available with a bypass fuse to allow sufficient current to pass to operate clocks, alarms and coded radios, but if any attempt is made to start the car the fuse will blow.

Battery mounted cut-off switchGAC3192X . . .£5.95
 Battery mounted cut-off switch with bypass fuse .GAC31921 . . .£8.95



In-line cut-off switches

These cut off switches need to be fitted into the main battery to starter cable. The body of the switch should be mounted securely to the car and cables fitted using the terminal kit.

Period cut-off switch

These are reproductions of the Lucas 'Battery Master Switch' which was a popular accessory on many British classics.

Period battery cut-off switch (short knob)1B2804 . . .£32.95
 Period battery cut-off switch (long knob)1B2804L . . .£32.95



Motorsport cut-off switches

Battery cut-off switches are obligatory for competition cars and should be fitted with a cable for remote access.

Battery cut-off switchTT7964 . . .£16.15
 Battery cut-off switch race spec (FIA approved) .TT7962 . . .£28.10
 Remote cable 6 footTT79621 . . .£27.95
 Spare key for switches TT7964 and TT7962 . .TT79641 . . .£4.36
 Terminal kit for battery cableTT7964TK . . .£8.95



TMG2930K

High capacity fuel pumps

The standard fuel pump may not be able to maintain adequate fuel flow and pressure at higher engine speeds, particularly with a tuned engine. The Facet range of fuel pumps will suit all standard and modified engines fitted with carburettors. They give constant fuel flow and pressure, even at high temperatures eliminating the problems associated with vapour lock. The pumps are available in a variety of specifications to suit the engine's fuel pressure and flow requirements. Further fine tuning of the fuel pressure can be easily achieved by the use of a separate fuel regulator, see website. With safety in mind we recommend fitting a fuel pump inertia switch kit, so that in the event of an accident fuel delivery is automatically cut-off. Fuel lines may require adapting to install the new pump, check pipe sizes to select the correct unions, additional unions may be required.

Cylindrical fuel pumps

Formerly known as interrupter type pumps, these heavy duty pumps can be fitted at the front or rear of the car and up to 600mm above the bottom of the fuel tank. Kits are supplied with mounting & 8mm unions, alternative size unions available.

Cylindrical fuel pump kit - road Silver TopTMG2930K . .£97.96
 (Up to 150bhp, flow rate: 30 gal/hr, 4.0-5.50 psi, unions: 8mm x 1/8 npt)
 Cylindrical fuel pump kit - fast road Silver Top . .MGS2930K . .£96.95
 (Up to 200bhp, flow rate: 35 gal/hr, 6.0-7.0 psi, unions: 8mm x 1/8 npt)
 Cylindrical fuel pump kit - competition Red Top .MGS2932K . .£99.95
 (Above 200bhp, flow rate: 40 gal/hr, 6.0-8.0 psi, unions: 8mm x 1/8 npt).
 Cylindrical fuel pump only - competition Red Top .TT2930 . . .£79.96
 (Above 200bhp, flow rate: 40 gal/hr, 6.0-8.0 psi, 1/4 npt threads).

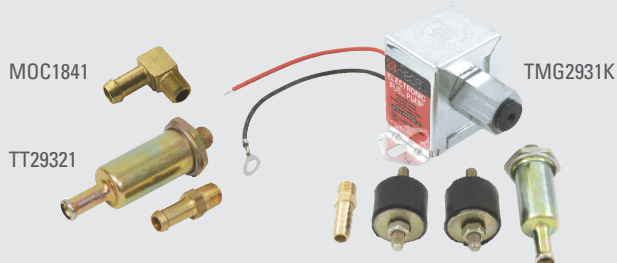

Solid state fuel pumps

These pumps should be mounted at the rear of the car (as they are designed to push fuel rather than draw fuel) and ideally below fuel tank level, although they will work up to 300mm above the bottom of the fuel tank. Kits are supplied with mounting & 8mm unions, alternative size unions available.

Solid state fuel pump kit - fast roadTMG2931K . .£57.95
 (Up to 150bhp, flow rate; 32 gal/hr, 4.5-7 psi, unions: 8mm x 1/8 npt).
 Solid state fuel pump only - fast roadMGS2931 . . .£40.96
 (Up to 180bhp, flow rate: 34 gal/hr, 7.0-10.0 psi, 1/8 npt threads).

Fuel pump unions

Use with the listed fuel pumps, please check thread and pipe size before ordering.

Straight union 1/4" (6mm) 1/8 nptFPA903B . . .£1.66
 Straight union 5/16" (8mm) 1/8 nptMOC1604 . . .£3.25
 Straight union 3/8" (10mm) 1/4 nptFPA904/B . . .£2.75
 90° union 5/16" (8mm) 1/8 nptMOC1841 . . .£5.95
 90° unions 5/16" (8mm) 1/4 npt (pair)TT2930A . . .£10.99
 90° unions 3/8" (8mm) 1/4 npt (pair)FPA902B . . .£10.25

Fuel filter union

Unions 1/4" (6mm) 1/8 npt (pair)TT29321 . . .£7.94



Upgraded brake pads

EBC brake products are renowned for their high quality and excellent performance. All grades of brake pad use Kevlar as the binding material rather than the traditional steel, this prevents the build up of corrosive brake dust that can damage alloy wheels.

Tested in rally cars, these pads are high friction, fade resistant with immediate pedal response with a fantastic wear life. We stock their Ultimax and upgraded Greenstuff and Yellowstuff high performance brake pads.



EBC brake pads

EBC Greenstuff brake pads are a high efficiency upgrade pad which will increase your car's stopping power by 20% over standard replacement pads.

- Greenstuff pads 10" wheels (998cc Cooper)GBP102G£33.95
- Greenstuff pads 10" wheels (Cooper S, 1275cc) . .GBP103G£33.95
- Greenstuff pads 12" wheels (1275cc to 1974, 1984 on) .STR505G . . .£32.95

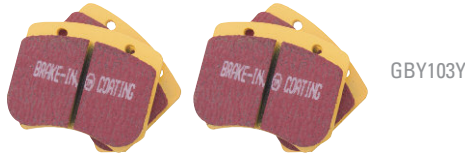

EBC Yellowstuff brake pads are formulated for fast road use and track day use. The higher heat range means they will resist the effects of brake fade under heavy braking.

- Yellowstuff pads 10" wheels (998cc Cooper)GBP102Y . . .£42.95
- Yellowstuff pads 10" wheels (Cooper S, 1275cc) .GBP103Y . . .£46.96
- Yellowstuff pads 12" wheels (1275cc to 1974, 1984 on) .STR505Y . . .£46.96



Mintex brake pads

Mintex M1144 is a hard wearing material ideal for fast road and track day use, giving good wear resistance and reduced fade under hard braking.

- Mintex M1144 set (1275cc to 1974 & 1984 on) .STR5051£50.95



Upgraded pads for 4 pot brakes

Choose from the following options, heavy duty Kevlar for every day use Green for fast road use and Yellow for fast road and track days. This range of performance pads will fit all known 4 pot calipers (except the Wilwood kit).

- Kevlar pads for 4 pot - roadGBP258KV . . .£29.95
- Greenstuff pads for 4 pot - fast roadGBP258G . . .£40.15
- Yellowstuff pads for 4 pot - fast road/track day . .GBP258Y . . .£56.95



Brake master cylinder

This large round reservoir brake master cylinder is suitable for Cooper S models or when upgrading your Mini to disc brakes.

- Brake master cylinder .70 boreGMC172£97.96



4 pot brake parts

Brake discs are something that will eventually need to be replaced, easy enough if you have a standard brake setup but not so easy if you have four pot solid or vented discs fitted to your Mini! These brake parts will fit KAD & Metro set ups. The high quality discs are suitable for all 8.4in vented applications. See Restoration section for our full range of brake components.

- Vented brake discs (each)MT1203£32.95
 - Stainless steel caliper piston 4 pot (each)MT5402£11.26
 - Seal kit for 4 pot calipers (1 caliper)GRK5003£9.49
 - Drive flanges (each)NAM6450F . . .£39.80
 - Split pins for 4 pot calipers* (set of 4)TMG307521 . . .£1.70
- (*Can also be used with Cooper models).

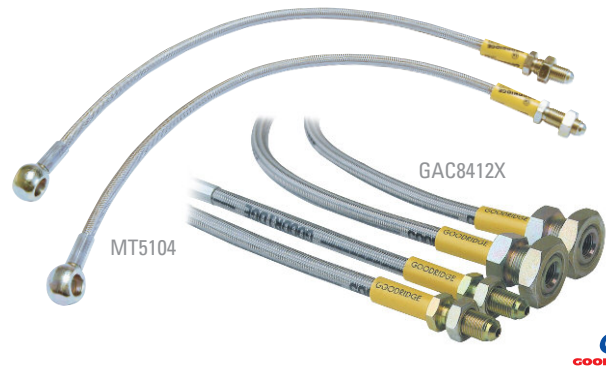

Braided brake and clutch hoses

The braking efficiency of your car can be increased by using high quality stainless steel braided brake hoses. Normal hoses expand slightly when brakes are applied. This expansion can now be reduced by using the stainless steel braided hoses, thus improving the feel of the pedal.

- Goodridge front braided hoses (pair)MT5102£20.95
 - Goodridge front braided hoses (pair) Metro 4 pots . .MT5103£47.95
 - Goodridge rear braided hoses (pair)MT5101£20.95
 - Goodridge rear braided hoses (pair) no metal pipe* .MT5104£22.45
- (*This hose goes from the subframe bracket to direct to wheel cylinder replacing the metal pipe).

- Braided brake hose set (all models*)GAC8412X . . .£39.80
- (*This is a universal kit that fits both disc and drum brake cars. On some models a banjo fitting is used on one of the hoses and it will bottom out, cut 3mm off the banjo bolt thread).

- Braided diaphragm clutch hoseGAC8446X . . .£9.95
 - Braided Verto clutch hoseGAC8447X . . .£12.25
 - Braided universal clutch hose*MT2401 . . .£22.96
- (*This universal clutch hose goes directly from the master cylinder to the slave cylinder, with banjo fittings at both ends).



Alloy rear hubs

These lightweight alloy hubs are billet machined and include bearings and long studs to fit brake drums with spacers or 'Superfin' alloy brake drums.

- Alloy rear hub (each) - blue21A2023XB ..£94.96
- Alloy rear hub (each) - red21A2023XR ..£94.96



Superfin alloy brake drums

A brand new superior lightweight alloy brake drum, pressure die cast with 25% more fins for extra cooling to improve braking efficiency and built-in spacer to give increased strength and reliability. Direct replacement for all post 1984 cars, Cooper S and 1275 GT's rear drums.

- Superfin alloy brake drums (pair)MT1210£89.95



TT3949

Remote brake servo kit

For those who find the brake pedal rather hard after driving more modern vehicles, these remote servo kits make braking easier by reducing pedal effort. Suitable for all single line brake circuits they are remote mounted and easily plumbed into the hydraulic and vacuum systems of the car. We offer both a Lockheed and aftermarket kit, both are supplied with mounting brackets and hardware.

- Remote brake servo kit LockheedTT3949£179.95
- Remote brake servo kit aftermarketTT3949Z£98.95

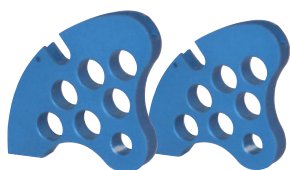

Alloy handbrake quadrant

Available in blue anodised alloy these handbrake quadrants are a great touch. Suitable for dry suspension models only.

- Anodised alloy handbrake quadrant (pair) - blue ..KAD1013282 ..£29.95

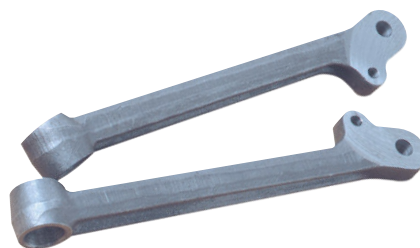

Negative camber lower arms

Adding negative camber improves the ability of the car to turn-in on a corner and as weight is transferred to the outside wheel, it will increase the contact area between the tyre and the road, giving you more grip.

These replacement lower arms offer varying degrees of negative camber over the standard item i.e. If a standard car leaves the factory with 1° positive camber, then fitting these arms will give 0.5° negative camber.

Because the front suspension consists of 2 unequal length arms, lowering the front ride height increases negative camber and conversely raising the front ride height will increase the positive camber.

- Negative camber lower arms 1.5° (pair)WPT9001X ..£61.94



On car adjustable lower arms

New design lower arms are now supplied with both rose joints and original bush type fittings. Adjustable on car lower arms make life much easier to set up for track days and if the car has been lowered and negative camber is required. (Supplied as a pair).

- Adjustable lower arms (pair)C-AJJ3363 ..£101.95



Heavy duty tie bars

Tie bars perform the important function of controlling the front to rear movement of the front wheels under acceleration and braking. With recent improvements in the braking components that are now available for the Mini, it is possible for the standard tie bars to flex. This reduces the stability of the car and produces a feeling that the car is wandering. The increased diameter of these heavy duty tie bars reduces this problem.

These tie bars also enable you to adjust the castor angle of the front suspension. The castor angle determines the amount of self centring of the steering. The more castor angle, the more effort is required to turn the steering wheel. 3° of castor is specified by Rover as the optimum setting.

- Heavy duty tie bars (pair)WPT9003X ..£25.96





FAM3968HX

Coil spring conversion

Designed 45 years ago the rubber cones that Sir Alec Issigonis and Alex Moulton gave were innovative and perfectly adequate for the day, they are a bit harsh for today's driving. An alternative is to replace the rubber cones with springs that are a direct replacement. Offered in two different spring rates.

- Softer coil spring kit - blueFAM3968X ..£305.47
(Front and rear coil spring kit that replaces the rubber cone).
- Firmer coil spring kit - redFAM3968HX ..£305.47
(Front and rear coil spring kit that replaces the rubber cone).



KGE100060SPK

Superpro polyurethane subframe bushes

For a fast road or road car the best compromise is to use polyurethane. Our Superpro poly bushes are the best compromise between subframe location and damping the road noise transmitted through the bodyshell.

- Front subframe tower pad kit subframe setKGE100060SPK £32.48
- Rear s/frame front mount kit split type axle set (to 1976) . .2A5818SPK . .£13.97
- Rear s/frame front mount kit large axle set (1976 on) . .21A2560SPK .£14.58
- Rear s/frame rear mount kit split type axle set (all models) .2A5818SPK . .£13.97



Solid front subframe mounts

Maximum subframe location is gained by using solid mounts. Ideal for a race car but will transmit more noise and road harshness into the bodyshell.

- Front subframe solid front mount* (each) . . .21A2624X . . .£26.50
- 1 Front subframe solid front mounts* (pair) . .CSTR641 . . .£18.95
- 2 Front subframe solid rear mounts** (pair) . .CSTR642 . . .£19.50
(*Fits to front valance. **Fits to toe board).
- 3 Front subframe solid tower mount setCSTR640 . . .£14.78
(Includes: 2 x tower oval pads & 2 x tower round pads).



Solid front subframe mounting kit

Red anodised alloy front subframe washers replace the turret mount pads and teardrop mount to the front valance, to reduce the movement of the front subframe, so helping the handling.

- Alloy front subframe washer kit (8 piece)MT1205 . . .£26.50



Alloy tower bolts

- Anodised alloy tower bolt - silver (pair)21A2596XSPR ..£59.95
- Anodised alloy tower bolt - blue (pair)21A2596XBPR ..£59.95
(For more subframe mount components see the Restoration section).



GAC8437X

Hi-Lo suspension kit

Change the ride height on your Mini. The original Hi-Lo kit allows you to raise or lower the height of your car without dismantling the suspension assembly. Homologated by the RAC and Rover for rallying.

- Hi-Lo suspension kitGAC8437X ..£117.95
- Adjustable cones kit (2 x cones, 2 x 21A423) . . .GAC84371 . .£49.96
- Extension rods (pair)GAC84372 . .£17.95
(Use with GAC84371 when fitting to rear suspension rear allen bar).
- Front allen barGAC84374 . .£4.03



GAC8432X

Adjusta-ride kit

The most popular way to lower your Mini, while allowing easy and quick adjustment when needed. Using a simple threaded knuckle bar and lock nut system, you can easily raise or lower your Mini, without having to remove the top subframe mounts or drill the rear valance. The knuckle joints have also been re-designed for extra strength and durability.

- Front adjusta-ride kitGAC8432X . .£66.95
- Rear adjusta-ride kitGAC8433X . .£99.95



Budget adjusta-ride kit

A complete car set of adjusta-rides in polished alloy, including rear bars.

- Budget adjusta-ride kitMT1301 . . .£95.95

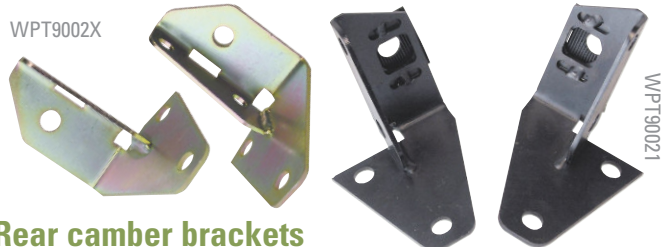

WPT9002X

WPT90021

Rear camber brackets

As with the front suspension, a small amount of negative camber on the rear suspension will improve handling. These brackets replace the standard outer radius arm bracket and will give 1 1/2° more negative camber. Unlike the front suspension, raising or lowering the rear ride height will not affect the camber angle. It is recommended that when more negative camber is used on the front, the rear should also be given more negative camber, to balance both handling and appearance.

- Rear camber brackets fixed 1 1/2° increaseWPT9002X . .£30.90
- Rear camber brackets adjustableWPT90021 . .£36.46



GAC84011X

GAC84041X

Adjustable shock absorbers

Shock absorbers are the first line in improving the handling of your Mini. We offer either Spax or Gaz front and rear adjustable shock absorbers for the Mini in either standard or lowered ride height option. Supplied in single units, but should be fitted as pairs for best performance on the car.

- Spax front standard height (each)GAC84011X . .£59.95
- Spax front lowered height (each)GAC84021X . .£58.25
- Spax rear standard height (each)GAC84031X . .£58.25
- Spax rear lowered height (each)GAC84041X . .£58.25



GAC8401XG

GAC8403XG

- Gaz front standard height (each)GAC8401XG . .£48.95
- Gaz front lowered height (each)GAC8402XG . .£48.95
- Gaz rear standard height (each)GAC8403XG . .£48.95
- Gaz rear lowered height (each)GAC8404XG . .£48.95



MT1302

MT1303

Gmax shock absorbers

Gmax shockers are a direct replacement but 30% uprated with a slight reduction in height to help stiffen up the ride without taking away from the comfort too much. Supplied in single units, but should be fitted as pairs for best performance on the car.

- Gmax shock absorber lowered front (each)MT1302£26.95
- Gmax shock absorber lowered rear (each)MT1303£25.96



SPK80ECF

Superpro polyurethane kits

Polyurethane is preferable to rubber as it gives improved location without having a detrimental effect on noise levels or a harsh ride. Added advantages are improved longevity and unlike rubber it is not affected by ultra violet light, water, salt, oil or petrol. The Superpro bushes come with a steel sleeve and grease where necessary.

Advice: For the best subframe location for your road car use Superpro bushes on the front subframe tower mounts with new standard mounts on the valance and toe board. Use Superpro poly for all rear subframe mounts.

Car kits (1965-76)

- Complete car kitSPK80ECK . .£62.05
(Inc: Front suspension, engine steady, rear subframe & steering column bushes).
- Complete front kitSPK80ECF . .£37.74
(Inc: Front suspension & engine steady bushes).

Car kits (1976 on)

- Complete car kitSPK80LCK . .£90.85
(Inc: Front suspension, engine steady, front subframe, rear subframe & steering column bushes).
- Complete front kitSPK80LCF . .£66.00
(Inc: Front suspension, front subframe & engine steady bushes).
- Complete rear kit (Inc: Rear subframe bushes)SPK80LCR . .£24.84

Suspension bushes

- Front lower arm bush kit (axle set)21A1882SPK . .£16.39
- Front tie bar bush kit (axle set)31G1155SPK . .£11.76
- Front upper arm & rear radius arm grease seal (each) .115702SP£1.81



SPCK19

Coil over kits

Developed between Spax and K.A.D. these coil over shock assemblies are simply the most versatile currently available for the Mini. Designed purely for road use they provide the ultimate in ride comfort and shock absorbance. The shock absorbers have fully adjustable gas cylinders with the added bonus of being able to adjust the responsiveness of the coil spring with the threaded collars. Front and rear shocks are in the kit containing all new brackets and fittings to successfully mount the shocks. As can be expected from K.A.D. and Spax, full and precise fitting instructions are included within the kit.

- Standard height coil over kitSPCK19£662.95
- Lower height coil over kitSPCK20£662.95



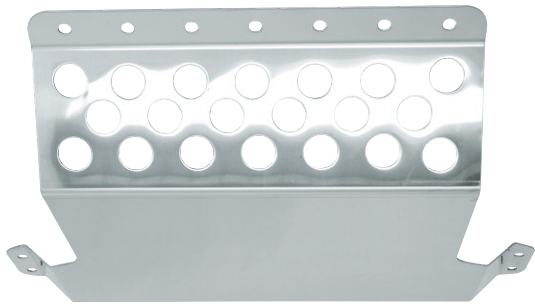

Sump guard

Protecting one of the most important components on your Mini must come high up on the agenda. The lowering of the car and speed bumps are not a great combination and the gearbox casing is quite expensive to replace. A lightweight stainless steel sump guard is the perfect way to protect the gearbox.

Stainless steel sump guardMT1207£57.95



Roof gutter moulding

This strip of chrome finish moulding is ideal for smartening the roof gutter of your Mini. The roof gutter moulding is supplied in a single length and simply clips onto the metal gutter edge.

Roof gutter mouldingGAC8494X ...£12.95

Body seam mouldings

These highly polished stainless steel seam mouldings will not only brighten up the exterior of your Mini but being stainless steel they are rust free and are also cheaper than the genuine original replacement items. Use BMP128MS stainless steel clips, to replace the standard painted items. Suitable for all cars from 1959 to current date.

Front seam mouldings (pair) . .8B12400£23.26
 Rear seam mouldings (pair) . .8B12401£22.40
 Seam mouldings clipBMP128MS . .£0.36

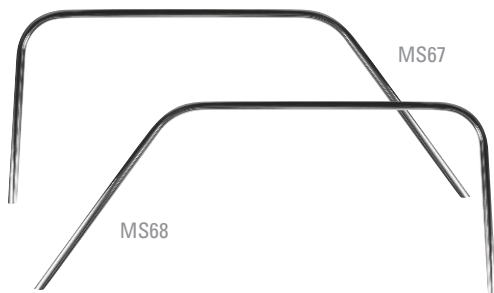

Upper door mouldings

Another styling accessory for those craving the retro look, these stainless steel mouldings are based on those fitted to the MkI and MkII Mini Coopers. Now available for cars with wind-up windows (ie: 1969 to current). If you think there is never too much bright work, then these are for you.

Top door trim lefthand (MkIII)MS67£33.95
 Top door trim righthand (MkIII)MS68£33.95
 Top door mouldings clip13H743£0.95



SmartScreen wash/wiper systems

These SmartScreen wiper kits allow intermittent wiper delay of between three and thirty seconds, programmed by using your existing wiper switch. SmartScreen wash/wiper kit allows you to have an automatic wiper system when using your electric screen-wash. All kits are easy to fit and come with full instructions.

SmartScreen wiper system

Positive earth (to 1969)GAC9222X ...£30.60
 Negative earth (pre 1969 converted)GAC9224X ...£29.56
 Negative earth (1969 on)GAC9221X ...£30.55

SmartScreen wash/wiper systems

Negative earth models (1969 on)GAC9225X ...£50.80

We now offer a bespoke Classic Mini SmartScreen wash/wiper system that simply plugs into existing multi-block connectors for simple plug & play wiper control. Suitable for all models up to 1997 with a column mounted wiper switch. It includes pre-wired multi-plugs that simply connect into the existing column switch loom.

Column mounted switch (to 1997)GAC9229X ...£51.00



MS85H

Heated windscreens

These high quality heated windscreens are the easy way to demist your windscreen - perfect for motorsport applications and those damp mornings.

“Demist your windscreen in around 20 seconds”

Manufactured to the latest British Standard these laminated windscreens feature a virtually invisible micro-wire element within the screen to effectively demist without impairing vision, it's the type of element used in many modern luxury cars. Installation is simple using standard rubbers and filler strip. We also offer wiring kits with relays to enable easy connection.

Available in two styles; *Monte Carlo*, a reproduction of the original style as used in the Mini's rallying heyday. This screen uses a dual zone circuit and requires fitting kit GAC40251. *Standard* style screens do not have the thick horizontal bars and are available in a range of tint options as listed below, these screens use a single zone circuit and require kit GAC4025.

Heated windscreen - green tint/green top tint . .MS85H£194.95
 Heated windscreen - green tintCZH4048H .£182.95
 Heated windscreen - clear24A2236H .£176.95
 Heated windscreen, Monte Carlo style - clear . .24A2236HM £247.96

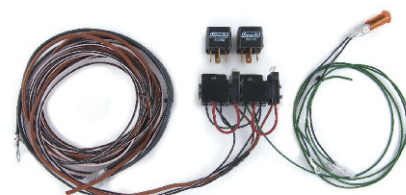

GAC40251

Wiring kits

Wiring kit - single zoneGAC4025 . . .£28.96
 Wiring kit - dual zoneGAC40251 . .£44.95



Kit inc:
WPA9021X, WPA9032S
WPA9028X, WPA9022X

Complete wiper, jet & bezel kit

This kit contains a full set of windscreen wiper arms & blades, wiper bezels, chrome washer jets and screw fitting wiper hole bungs.

Complete wiper jet & bezel kitWPA9067X . . .£49.96



Chrome wiper wheelbox bezel kit

This is a very simple kit to fit but it goes a long way to improving the appearance of the front end, especially if you've just resprayed your Mini.

Chrome wiper wheelbox bezel kitWPA9028X . . .£8.26



Wiper hole plugs

Spruce up the scuttle panel with these stainless steel rubber backed plugs.

Wiper hole plugs (each)WPA9032X . . .£5.00

Wiper hole plugs screw fitting (pair)WPA9032S . . .£8.15



Stainless wipers

This kit is a direct replacement for the rather boring black wiper arms that are supplied on recent Minis. Available for either LHD or RHD cars.

Wiper arm kit RHDWPA9022X . . .£24.95

Wiper arm kit LHDWPA9023X . . .£24.95



Chrome washer jet kit

The original washer jets are not all that helpful at cleaning the Mini's screen, so upgrading to twin nozzle chrome washer jets will improve things greatly.

Chrome washer jet kitWPA9021X . . .£9.46



WPA9006X

Bumper and override kit

If you want to give your car the retro look, overrides and corner bars are a must. We supply 2 kits, a complete bumper and override kit and an override kit.

The complete kit contains: 2 bumper blades - pre drilled for corner bars, 4 overrides, 4 corner bars and all hardware giving the MkI look. The override kit contains: 4 overrides and hardware to give the MkII look.

For cars made from 1980 on, rear fog lamps were fitted as standard so you'll need a relocation bracket, (RHD only).

Bumper & override kit (MkI)WPA9006X . .£199.94

Override kit (MkII)WPA9005X . .£78.95

Override components are also available separately:

Override chrome RHF & LHR* (MkI)14A9923 . . .£19.96

Override chrome LHF & RHR* (MkI)14A9924 . . .£19.96

(*With holes for corner bars).

Overrides stainless steel** (MkII)14A8738SS . .£20.95

**Without holes for corner bars).

Corner bar RHF14A9877 . . .£12.95

Corner bar LHF14A9878 . . .£12.95

Corner bar RHR14A9919 . . .£11.95

Corner bar LHR14A9920 . . .£11.95

Override fitting bracket14A7598 . . .£0.90

Override fitting boltSH605101 . . .£0.55

Bumper to corner bar distance piece14A9879 . . .£1.30



Rear fog lamp relocation bracket RHDGAC9400X . .£15.95



GAC9212X

GAC9213X

Screen washer kits

The electric washer kit converts your existing manual pump washer system. Both kits are supplied complete with fittings, pump and plastic washer bottle.

Screen washer conversion kit manualGAC9212X . .£51.74

Screen washer conversion kit electricGAC9213X . .£23.95





Chrome exterior handles

Enhance the appearance of your Mini with chrome plated exterior handles. The sets comprise of two push button handles and a boot handle with matched keys and locks. Choose either a MkI or MkIII boot handle.

- Chrome handle set with MkI boot handleCZH1784S . . .£90.95
- Chrome handle set with MkIII boot handleWPA9019X . . .£54.95



Door handle escutcheons

An ideal way to protect your paintwork and smarten the appearance of the Mini.

- Plain door handle escutcheons (pair)WPA9011X . . .£5.95

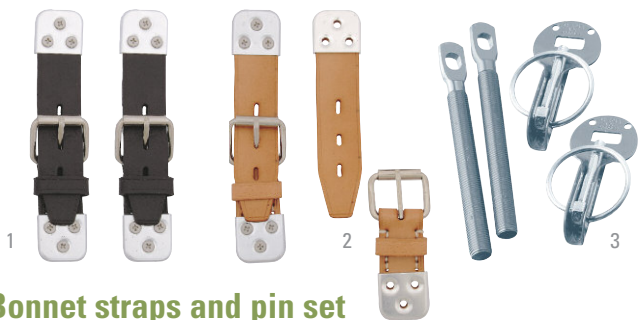

Bonnet straps and pin set

Works style bonnet straps add a classic race & rally look to any classic car. Originally used by the factory BMC Special Tuning department to prevent unwanted opening of the bonnet these straps are perfect for those recreating that retro rally car look or just wanting peace of mind. Manufactured from high quality leather with stainless steel end plates. Available in tan or black either individually or in pairs. Or choose a set of stainless steel bonnet pins to give a modern competition look. Some bodywork modification is required to enable their use.

- Bonnet strap black (single)222-601 . . .£13.94
- 1 Bonnet strap set black (pair)222-602 . . .£25.96
- Bonnet strap tan (single)222-729 . . .£13.94
- 2 Bonnet strap set tan (pair)222-728 . . .£25.96
- 3 Stainless steel pin setMRAC801S . . .£16.00



Door wind deflectors

These wind deflectors fit neatly into the door window channel and allow you to drive with the window open slightly for extra ventilation without being buffeted.

- Door wind deflector (pair)MT9316 . . .£50.95



Quick release bonnet hinges

Designed for the MkIII, the hinges enable you to easily remove the bonnet for engine work, while not increasing the risk of the bonnet going into orbit.

- Quick release bonnet hinges (MkIII)MSSK019 . . .£32.40



Chrome horn

Keeping the under bonnet area looking its best is always easier when you have a few chrome parts fitted. Direct replacement horn finished in luscious chrome.

- Chrome classic horn 105mmMT9143 . . .£15.25



Air horn kit

Let them know your coming.

Note: May not be legal for road use, please check local regulations.

- Dual air horn kitGAC9978X . . .£33.95



MkI number plate kit

Put one of these on your Mini and fool people into thinking that it's a MkI. Our hinged plate kit includes all fittings (except light unit). Choose from either a black or chrome finish lamp unit.

- Number plate kitGAC8438X . . .£32.95
- Number plate lamp unit - chrome127916 . . .£20.95
- Number plate lamp unit - black127916BLK . . .£20.95



Number plate surround

Manufactured from durable injection moulded ABS plastic, this chrome finish surround can be fitted in minutes to the front or rear of the vehicle.

- Chrome number plate surroundGAC0070 . . .£11.15



MkIII number plate lamp housing

- Chrome metal number plate lamp housing (MkIII) .GAC4614 . . .£15.55



British Leyland style door mirrors

Rectangular polished stainless steel door mirrors suitable for all Minis with a choice of either flat or convex glass. Supplied with angled base and fittings. Use adaptor plates to fit to doors with late type captive nuts.

- Door mirror convex glass RHGAM215A£23.95
- Door mirror convex glass LHGAM216A£23.95
- Door mirror flat glass RHGAM217X£24.95
- Door mirror flat glass LHGAM218X£24.95
- Adaptor plate kit RHCZH1626£6.25
- Adaptor plate kit LHCZH1625£6.25



Rover style door mirrors

These late type plastic door mirrors are available in black plastic or primed. Later models have the plastic door mirror painted in either white or body colour. Pre-painted mirrors are no longer available. Primed mirrors should be purchased and painted to suit your car.

- Plastic door mirror RH - blackJPC9848£50.95
- Plastic door mirror LH - blackJPC9849£50.95
- Plastic door mirror RH - primedCRB10184LML £62.45
- Plastic door mirror LH - primedCRB10185LML £62.45



Chrome Cooper door mirrors

Replacement chrome door mirror that fit the original captive nut mountings on the car so no need to drill extra holes.

- Chrome Cooper door mirrors (pair)MT9142£61.96



Aluminium racing mirrors

These racing mirrors echo a bygone era of motorsport. Available in polished or satin finish with a black base, both feature a flat glass and single bolt fitting.

- Polished alloy mirror (each)MT9314£22.96
- Satin finish alloy mirror (each)222-355£22.96

Bullet style mirrors



Long base mirrors

These feature a 3.75" long base and are fixed with two screws from inside the door at 2" centres. Suitable for left or righthand mounting.

- Chrome flat glassGAM105£14.95
- Chrome convex glassGAM105C ..£16.96



Long base racing mirror

This mirror features a larger 4.25" lens with a 3" base. It is externally fitted to the mounting bracket. Suitable for left hand or right hand mounting.

- Chrome flat glass222-390£27.95



British Leyland style mirrors

These feature a 3.75" long base and are plinth mounted as per British Leyland style door mirror. They are interchangeable with British Leyland type door mirror. Use adaptor plates to fit to doors with late type captive nuts.

- Chrome flat glass RHGAM106£49.96
- Chrome flat glass LHGAM107£49.96
- Adaptor plate kit RHCZH1626£6.25
- Adaptor plate kit LHCZH1625£6.25



Dual base mirror

Dual base mirror is supplied with two bases; the short base is 2.25" long and the large is 4.5" long, the mirror can be fixed to the car using either base to cover previous mirror fixing holes. Suitable for left or righthand mounting.

- Dual base chrome flat glass222-372£34.96



Racing door mirrors

These great looking chrome bullet door mirrors are a must! They look great on the Mini and include adaptor plates to easily fit door skins with captive nuts.

- Bullet racing door mirror RH (MkIII on)GAM108£24.95
- Bullet racing door mirror LH (MkIII on)GAM109£24.95
- Bullet racing door mirror (pair) (MkIII on)GAM108/9 ..£47.95



H4 Halogen HEADLAMPS

LONDON 020 8867 2020
BRADFORD 01274 539 999
BRISTOL 0117 923 2523
MANCHESTER 0161 480 6402
PARIS 01 30 80 20 30
WEBSITE moss-europe.co.uk



Ultimate Night Time Vision

Fitting a Wipac halogen headlamp conversion is one of the most worthwhile improvements you can make to your Classic. Wipac design and manufacture exterior lighting products for the world's premium car makers. These classic style lamps use powerful halogen bulbs combined with an improved convex lens design. Resulting in a superior light beam and pattern to that of the original lamp units. These lamps are available with or without a pilot (side light) and for left or right hand drive vehicles.

The Wipac kits include two lamp units and two 60/55w halogen bulbs. The units can be used with either standard H4 bulbs or replace them with blue tinted, or super white xenon. Super white xenon are approximately 30% brighter than the standard bulb.

WIPAC

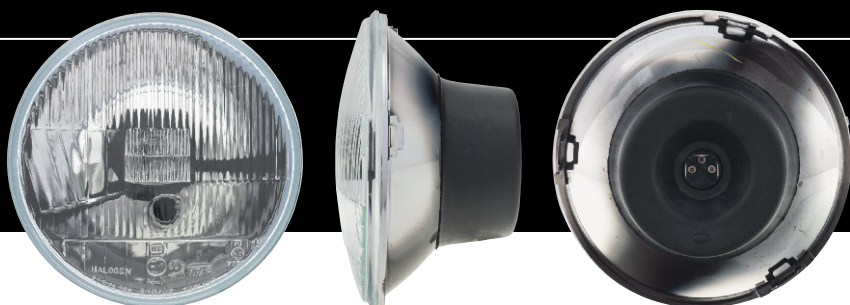

See page A37 for Wipac kits and H4 bulb options



Dummy filler neck

Can't quite stretch to the price of the right hand petrol tank but would like people to think you can? Then we have just the thing for you. A filler neck which just screws onto the panel. The kit includes a template for correct positioning on the bodywork.

Dummy filler neckGAC8436X ...£13.96

Fuel caps



Aston locking fuel cap sets

The classic Aston cap sets fit directly to the tank filler neck and uses a removable inner cap for refuelling. They are not suitable for use with fuel injected Minis (SPi & MPi) as they require a non-vented cap.

Aston cap set vented - alloyGAC4123X ...£158.95

Aston fuel cap covers

The Aston cap (GAC4127X) fits directly to the tank filler neck and uses a removable inner cap for refuelling. The Aston cap (MCC299) fits to an existing filler cap and both cap cover and cap are removed for refuelling. Both of these cap covers are compatible with our standard locking fuel caps GSS154, vented or WLD100310, non-vented. Fuel caps sold separately.

Aston cap cover only - large (90mm) - chrome ...GAC4127X ...£23.95

Aston cap cover only - small (75mm) - alloy ...MCC299 ...£39.95

Locking fuel caps

Most carburettor models will require a vented cap whereas fuel injection models (SPi & MPi) require a non-vented cap.

Standard locking filler cap vented (green)GSS154£13.96

Standard locking filler cap non-vented (red)WLD100310 ...£13.96



General switches

We have a range of period looking switches for general purpose use. Use a momentary switch for starters, horns, washers, and the 1 position for auxiliary lamps.

- Push button switch momentary3H3058£14.95
- Toggle switch momentaryGWW102X ...£17.20
- Toggle switch on/offRTC430A ...£4.96
- Pull switch on/off - white illuminationGAE132 ...£12.25
- Pull switch on/off - green illuminationGAE132G ...£12.25
- Pull switch on/off - red illuminationGAE132R ...£12.25
- Pull switch on/off - yellow illuminationGAE132Y ...£12.25
- Fuse holder inlineUKC4446 ...£1.75

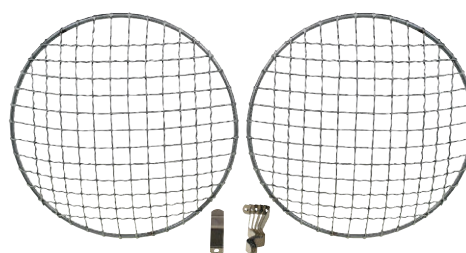

Chrome headlamp stone guards

Add some protection to your headlamps with these period styled chrome headlamp guards. A good excuse to fit more chrome.

Chrome headlamp stone guards (pair)GAC8000X ...£9.95



Headlamp rims

As fitted to the original Radford de Ville and other luxury Minis of the 1960's, these high quality chrome headlamp rims have a different profile to standard giving the impression of being wider.

For Mini owners who think their car is getting a little bit overweight, aluminium headlamp rims are available with an anodised finish, to replace the standard steel on brass rim, not suitable for Clubman models.

Chrome headlamp rim (pair)WPA9038X ...£49.96

Alloy headlamp rims (each)500929ALLOY ...£20.95



Headlamp peaks

As fitted to the original Radford de Ville and other luxury Minis of the 1960's, these high quality peaks change the profile of your Mini headlamps.

Headlamp peaks (pair)GAC7999X ...£10.75



Lamp brackets & switch

The right parts to fit your lovely new spot and fog lamps with.

- Spot lamp bracket OE Rover typeXBU10044 ...£14.95
- Stainless steel spot lamp bracket (pair)GAC4612 ...£13.20
- Stainless steel original works style lamp bar kit ...GAC4616 ...£59.20
- Fog lamp relocation bracket (fitting overrider kit) .GAC9400X ...£15.95

A period style toggle switch for your lovely new lamps. It can also be used for other electrical accessories.

- Toggle switch off/onRTC430A ...£4.96
- Toggle switch off/on/onBCA4294 ...£12.95





Auxiliary reverse & fog lamps

Many classics were not originally fitted with reverse or rear fog lamps. These universal polished stainless steel lamps measure 55mm x 110mm (2" x 4.5" approx.) and can be easily fitted, ideal for mounting under bumpers etc... Fog lamps require an illuminated switch mounted visibly on the dashboard.

- Auxiliary fog lampGAC4608 ...£17.95
- Auxiliary reverse lampGAC4609 ...£17.95
- Bulb replacement 12V 20WGAC4608B ...£2.95



MkI rear lamp conversion

The MkI rear lamp is probably the largest part of a true retro look. The conversion has been made easier with the arrival of the adaptor plates that can be welded into the original MkII or MkIII light unit apertures.

- Adaptor plates (pair)GAC8452X ...£24.95
- MkI lamp unit RHBHA4228 ...£49.96
- MkI lamp unit LHBHA4229 ...£49.96



Jewel rear lamps

Something a little different! Jewel rear lamps certainly stand out from the rest. Supplied as a complete set with bulbs.

- Rear jewel lamp setMT3700 ...£56.10



Clear rear lens conversion

This very popular conversion can be combined with our other clear lens kits (clear front indicators and side repeaters) completing the total clear lens look, or fitted on its own, giving the Mini a contemporary appearance. Lenses are sold as a pair of stop/tail & indicator lenses without bulbs. Suitable for all Minis from 1976-99 with 2 piece lenses on Lucas type bases. Reverse lamp lenses are also available separately.

- Clear rear lens set (pair)GAC4617 ...£14.95
- Bulb twin filament red stop/tail (2 required) ...GLB380R ...£1.96
- Bulb single filament amber indicator (2 required) .GLB343£1.75
- Lens reverse lamp RHXFJ10028 ...£13.96
- Lens reverse lamp LHXFJ10029 ...£13.96



Spot & fog lamps

Give your Mini a classic rally look with our range of lamps, and see where you're going at night! All use an H3 replacement bulb GLB453 and can be fitted using the universal wiring kit GAC4027 see below.

- Chrome 5.5" angel eye spot lamps (pair)GAC4601 ...£51.00
- Chrome 5.5" angel eye fog lamps (pair)GAC4602 ...£49.96
- Stainless steel 5" driving lamps (pair)GAC4619 ...£37.96



- Chrome 5.5" standard pattern spot lamps (pair) .GAC4610 ...£42.47
- Chrome 5.5" standard pattern fog lamps (pair) .GAC4611 ...£48.95
- Replacement bulb H3GLB453£3.60
- Wiring fitting kit (universal)GAC4027 ...£11.50

Wipac 5.5" chrome plated driving & fog lamps, with tough plastic lens covers.

- Driving lamp (pair) - WipacWPS6007 ...£29.95
- Fog lamp (pair) - WipacWPS6078 ...£24.95



Indicator clear lens kits

Early style lens kits

This early style clear lens kit is available with either beehive or flat glass lenses which are held in by a chrome rim, perfect for the retro look. Each kit contains two glass lenses, two retainer rims and two orange bulbs.

- Early beehive clear lens kitWPA9026X ...£15.40
- Early flat clear lens kitWPA9030X ...£33.95
- Replacement bulbGLB343£1.75



Later style lens kit

For 1984 on models, this kit contains 2 clear lenses, amber bulbs and screws.

- Clear (screw ret.) indicator lens kit (1984 on) ...WPA9027X ...£6.95
- Replacement single filament bulb - amberGLB343£1.75
- Lens finisher bezel chrome (each)CDU3374CR ...£7.96



Clear wing repeater kit

Also available is a clear wing repeater kit for later cars (1984 on) including a pair of lenses and amber bulbs.

- Clear wing repeater kit (1986 on)WPA9043X ...£8.35
- Wing repeater replacement bulb - amberGLB501X ...£1.15
- Wing repeater wiringMT3703 ...£25.96
- Side repeater bezel chrome (each)AHU2592CR ...£7.60

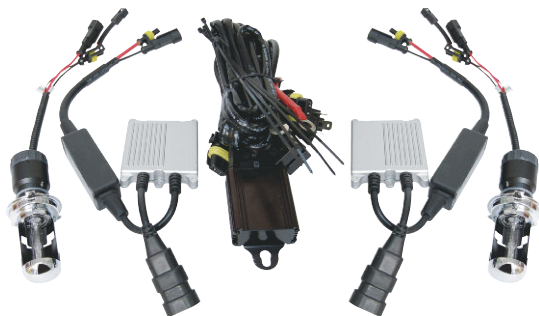

Headlamp kits - HID H4 conversion

HID (High Intensity Discharge) headlamps are a breakthrough in vehicle lighting technology and are found in many current production cars. Now classic cars can benefit from this technology with this HID bulb conversion kit.

- Higher light output - up to 3 times brighter than halogen
- Safer night driving - brighter light with improved range
- Nominal 3.5 amp draw when on, ideal for dynamo equipped cars
- Longer lasting bulbs - at least 6 times longer than halogen

Fitment note: This kit does not include the headlamp units. If your car is already fitted with H4 halogen headlamps, this kit is a direct fit. However, if your car is fitted with sealed beam units, P45 or other types of headlamps, you will need to purchase an H4 halogen conversion separately. Negative earth only. For more information, please check our website. HID bulb kits are sold for off road use only.

HID bulb conversion kit - H4GAC4022H .£147.95



Halogen headlamp replacement bulbs

- Standard halogen H4 60/55 watts (each)GLB472£3.84
- Halogen H4 100/90 watts (each) (check regulations) .GLB484£5.75
- Xenon H4 60/55 watts (pair)GLB472X£8.45
- Xenon H4 60/55 watts - blue tint (pair)GLB472BLU ...£8.35
(Xenon bulbs are up to 30% brighter than the standard halogen bulb).



Period style lamps

These outstanding reproductions of the original Lucas L576 units are available as either a driving lamp with a clear lens or a fog lamp with a fluted lens in either a base or back mounting. Use a back mounted fluted lamp as a works style reverse lamp.

- Driving lamp with clear lens (each)MM162-700 .£72.95
- Front fog lamp with fluted lens (each)MM162-800 .£72.95
- Back mounted lamp with fluted lens (each)BHA4399 ...£72.95
- Back mounted lamp with clear lens (each)57H5322£72.95

We stock replacement units, so you don't have to buy the whole lamp again.

- Replacement lamp unit with fluted lens (each) .ACG5179 ...£29.95
- Replacement lamp unit with clear lens (each) .57H5015£29.95
- Replacement bulb driving lamp (each)GLB185£4.20
- Replacement bulb fog lamp (each)GLB323£4.90



H4 halogen headlamp conversions

GAC4023Z

Fitting a halogen headlamp conversion is one of the easiest and most worthwhile improvements you can make to your Mini. Powerful halogen bulbs with an improved lens design result in a superior light beam without blinding oncoming traffic. No matter how fast your car is you can only travel as quickly as your vision allows. For the ultimate night vision use one of these H4 conversion kits with our HID conversion kit (GAC4022H).

- Lucas H4 headlamp conversion kit RHD (pair) ..GAC4023 ...£85.94
- Wipac H4 headlamp conversion kit RHD (pair) .GAC4023Z ...£39.95
- Wipac H4 headlamp conversion kit LHD (pair) .WPS4699 ...£52.96



GAC4600

GAC4022X

Crystal halogen headlamp kits

These crystal lamps give your car a modern look with the beam pattern moulded into the reflector rather than the lens. Manufactured with a tough polycarbonate clear lens they are available with or without pilot lamp, and are a direct replacement for original 7" sealed beam or H4 conversion lamp units. Headlamp bulbs are supplied separately.

- Crystal halogen without side light kit** (pair) ...GAC4022X ...£41.95
- Crystal halogen with side light kit** (pair)GAC4023X ...£44.95
(**'E' marked for legal road use, use dipping H4 bulbs. RHD only).
- Crystal halogen with angel eye kit* (pair)GAC4600 ...£51.95
- Crystal halogen kit* (pair)GAC4615 ...£35.70
(*NOT 'E' marked for legal road use, no dip pattern).



117-515

Headlamp relay kits

Fitting halogen headlamps puts high loads on electrical components. These kits allow easy installation of relays into the headlamp circuit allowing for the high current circuit to be run through the relay. Fitting relays in headlamp circuits protects your wiring and reduces the resistance in the circuit allowing full power to the lamps. Kits include relays and fittings. The single relay kit can also be used for wiring spotlamps, horns and other electrical accessories.

- Headlamp relay kit 2 relay117-515£29.95
(Inc: 2 relays, pre-wired relay holders, fitted terminals, fittings & instructions).
- Relay kit 1 relayGAC4027 ...£11.50
(Inc: 1 relay, non-assembled wiring, terminals & fittings).
- PVC tubing black pre cut metre504806£0.70





MRAC402

Works style wheel arch sets

These 'Works' style wheel arches are replicas of the works style of arch fitted to race and rally Minis in the sixties and give your car that great retro look. Group 2 arches are also available for 6" wheels with an extra lip on the outer edge of these arches means a chrome finisher can be fitted GZF105 for deluxe or GZF107 for flat. Group 5 arches are suitable for cars with up to 7" wheels. Made from fibreglass with a black gel coat finish and require drilling to fit.

- Group 2 arch set no lip - 1.75" wide/5" wheel . . .MRAC401 . . . £63.95
- Group 2 arch set with lip - 3.5" wide/6" wheel . .MRAC402 . . . £49.96
- Group 5 arch set no lip - 3.5" wide/7" wheel . . .MRAC405 . . £107.95
- Chrome finisher deluxeGZF105£8.95
- Chrome finisher flatGZF107£5.95



WPA9101

Sports pack wheel arch kit

As fitted to Rover sports pack Minis, this very popular wheel arch kit is made from fibreglass and includes fixing studs & rubber edge trim. Sill trim not included. These arches protrude 3.5in. Some modification to the front metal arches may be necessary if fitting 13in wheels to non sports pack Mini.

- Sports pack wheel arch kit fibreglassWPA9101 . . £135.54
 - Sill finisherDDJ10002 . . £20.50
- (Rubber strip fitting along sill between front and rear arch extensions).



AJM1117Z

Plastic wheel arch kits

These plastic wheel arch extension kits were standard on many Minis, however if they are too subtle for you, we also stock various wider options.

- Wheel arch kit - blackAJM1117Z . . £25.96

Kit AJM1117Z includes (also available separately)

- Wheel arch extension front righthand - black . . .CZH4312Z . . £5.56
- Wheel arch extension front lefthand - black . . .CZH4313Z . . £5.56
- Wheel arch extension rear righthand - black . . .CZH4314Z . . £5.56
- Wheel arch extension rear lefthand - black . . .CZH4315Z . . £5.56
- Sill finisherCZH4316Z . . £3.90
- Rivet for wheel arch (quantity as required)DYQ100140 . . £1.66



Classic wide wheel arch kit

The following wheel arches are designed to enhance the look of your Mini giving it a wide sporty stance. Supplied with piping they can be sprayed in body colour. These arches are suitable for wheels of up to 5" width. Some adjustment of the front wheel arches may be required to allow fitment.

- Classic wide wheel arch kitWPA9001X . . £86.95



GAC8449X

Stainless steel wheel arch cover kit

To brighten up the exterior of the Mini why not add these quality stainless steel arch extension covers which screw onto the standard arch extensions.

- Stainless steel wheel arch cover kitGAC8449X . . £62.95
- Stainless steel moulding (pair)GAC84491X . . £29.95

MT7122



Wheel spacers

These spacers will allow small adjustments to be made to the offset (to ensure wheel and tyre clearance) when fitting alloy wheels. Can also be used to space your wheels out to fill the wheel arches. When choosing the width of the spacer ensure that it will leave adequate thread length for secure wheel fitment.

- 3mm wheel spacer (pair)TT6901 . . . £13.94
- 6mm wheel spacer (pair)TT6902 . . . £17.95
- 9mm (3/8in) solid wheel spacer with stud kit . . .MT7120 . . . £23.95
- 19mm (3/4in) solid wheel spacer kit with stud kit .MT7121 . . . £26.50
- 25mm (1in) solid wheel spacer kit with stud kit .MT7122 . . . £29.95



CAT10044



AJM164

Rear mud flaps

These are genuine Rover mud flaps as fitted to later Minis.

- Rear 'Mini' mud flap setAJM164 . . . £37.96
- Rover 'Mini Cooper' rear mud flap setCAT10044 . . £39.60



MT7118

Sports pack style alloy wheel

An 'exact' copy of the alloy wheel fitted by Rover on the sports pack multi point injection Mini. Can be used to replace damaged sports pack wheels or to transform your standard Mini to sports pack specification. Some modification to the front arches may be necessary if fitting to non sports pack Minis, together with the arch kit WPA9101, see opposite. Centre caps and wheel nuts supplied separately.

- Sports pack style 13" x 6" (each) - silverMT7118**£90.95**
- Wheel nut for sports pack wheel (each)RRD10009**£3.05**
- Green cap with Mini logo (each)DTC100680MNH **£10.40**



88G337Z

GAC8215X

10" Cooper style alloy wheel

These great looking 4.5J wheels recreate the classic look of the early Cooper steel rims, they look smart on any Mini going for the classic look. Our chrome hub caps are the perfect complement to these wheels.

- Cooper style alloy wheel 10" (each)GAC8215X**£66.95**
- Chrome wheel nut for 10" Cooper style wheel (each) .GAC8210XNT . . .**£1.13**
(Chrome plated nut. Use without hub cap).
- Chrome hub cap (each)88G337Z**£20.95**
- Plain wheel nut for 10" Cooper style wheel (each) .88G322**£0.65**
(Plain steel nut. Use with hub cap).



WPA9104X

8 spoke alloy wheel with polished rim

This 12" eight spoke alloy wheel has a polished rim, and an offset designed to complement the wheel arch set WPA9001X, see opposite. Supplied with centre caps only.

- 8 spoke 12" x 5" (each) - silverWPA9104X**£83.95**
- Chrome dome nut (each)WPA91042X**£3.65**



GAC8210X

GAC8313X

8 spoke alloy wheels

A carefully selected set of alloy wheels will not only enhance the appearance of your Mini, but could also help improve the handling by allowing the fitment of wider section tyres. Wheels are supplied without wheel nuts.

- 8 spoke alloy wheel 10" x 5" (each) - silverGAC8210X . . .**£76.96**
- 8 spoke alloy wheel 10" x 6" (each) - silverGAC8208X . . .**£57.95**
- 8 spoke alloy wheel 12" x 5" (each) - silverGAC8212X . . .**£64.96**
- 8 spoke alloy wheel 13" x 6" (each) - silverGAC8313X . . .**£89.95**
- Wheel nut for 10" 8 spoke wheel (each)GAC8210XNT . . .**£1.13**
- Wheel nut for 12" & 13" 8 spoke wheel (each) . .AHA8785**£1.15**



MT7104

MT7108

Revolution alloy wheels

The Revolution 4 spoke and the 5 spoke RFX wheels are supplied without wheel nuts. The black alloy wheels feature black spokes with a silver rim.

- Revolution 4 spoke 6" x 10" (each) - blackMT7101**£64.96**
- Revolution 4 spoke 6" x 10" (each) - silverMT7102**£57.14**
- Revolution 4 spoke 5" x 12" (each) - blackMT7104**£63.95**
- Revolution 4 spoke 6" x 12" (each) - chrome . . .MT7112**£117.95**
- Revolution 4 spoke 7" x 13" (each) - blackMT7114**£89.95**
- Wheel nut for 4 spoke 10" & 12" wheel (each) . .MT7100X**£2.35**
- Wheel nut for 4 spoke 13" wheel (each)MT7100**£1.98**

Revolution 5 spoke RFX alloys

- Revolution 5 spoke RFX 5" x 12" (each) - silver .MT7108**£70.94**
- Wheel nut for 5 spoke RFX wheel (each)GAC8210XNT . . .**£1.13**

Please note: All wheels are sold individually unless otherwise stated, ensure you use the correct wheel nuts for each wheel.



Chrome hub cap

This chrome reproduction hub cap fits any 10" wheel for a stock, very original look to your Mini.

- Chrome hub cap for 10" wheels (each)88G337Z**£20.95**





Classic decals

A small selection from our range of decals available for your car, please refer to the Restoration section for a listing of the exact requirements for your model.

- 1 BMC rosette (external)CRTR208£5.54
- BMC rosette (internal)CRTR204£5.54
- 2 BMC Special Tuning rosette (external)CRTR207£5.54
- BMC Special Tuning rosette (internal)CRTR207A£5.54
- 3 Leyland Special Tuning Abingdon - green ...CRST153£2.35
- Negative earth stickerCRST113£1.66
- Unipart filter stickerCRST119£2.15
- Tudor water bottle stickerCRST124£1.25
- Triplex screen stickerCRST125£1.96
- 4 British Leyland house stickerCRST126£0.95
- Lucas coil stickerCRST156£2.30
- 5 Leyland Special Tuning stickerCRST110£1.96



Chassis plates

- Austin Morris group chassis plate*CRCP339£4.96
 - 1 Commission plate*CRCP301£2.86
 - 2 Engine number plate (blank)*CRCP343£2.65
- *(It is up to the purchaser to stamp the correct numbers onto the plates).



Replica Broadspeed name plate

- Broadspeed name plateCRCP384£8.45



Spot/fog lamp cover with Lucas logo

This authentic period style, vinyl spot/fog lamp cover features the Lucas lion logo. Suitable for 6" diameter lamps with a small clear window to see if the lamps are on or off.

- Lucas spot/fog lamp cover - black (each)162-705£44.95



Union flag roof decal

Create an unmistakable patriotic statement with this high quality Union flag roof decal. Essential for those continental jaunts. For white roof cars only.

- Union flag roof decalDAF105120£51.00



Classic badges

A range of quality badges suitable for both grille and badge bar mounting.

- 1 BMC Drivers ClubGAC9967X£77.95
- 2 British Motor Racing Marshalls ClubGAC9987X£70.96
- 3 British Racing and Sports Car ClubGAC9969X£22.75
- 4 BARC BrooklandsGAC9966X£22.75
- 5 Festival of BritainGAC9985X£69.95
- 6 England Union flag toothedGAC8043X£28.96
- 7 Queen Elizabeth CommonwealthGAC9968X£93.95
- 8 St. ChristopherGAC9970X£63.95
- 9 RAC diamondGAC9971X£75.95
- 10 RAC round laurelGAC1028X£75.95
- 11 RAC toothedGAC8045X£28.96
- 12 UK mainland105-432£8.12
- 13 Union chequered flag (42 x 24mm)DAG000070MMM £31.94
- 14 Union flag screw fit (30 x 50mm)GAC4100£6.60
- 15 Union flag screw fit (35 x 57mm) - chrome .GAC4101£12.95
- 16 Union flag stick on (pair)CRST186£3.95
- 17 Union flag magneticMM215-330£9.20
- 18 Union flag 'flying'DAG000080MMM £19.96
- 19 Union flag stick on - chromeGAC4100CR£9.16
- 20 GB letters stick on - chromeMRD1034SA£12.80
- 21 GB letters set 3 piece - chromeMRD1034A£10.15



Badges (MkI & MkII)

An important feature for any retro conversion, these badges are just a few of the most popular of the total fitted to the Mini during its long history. An array of different badges were fitted to both Morris and Austin Minis during their production.

- 1 Austin Cooper and S bonnet badge (MkI)24A71£10.16
- 2 Morris Cooper and S bonnet badge (MkI)24A72£27.55
- 3 Morris Mini bonnet badge (MkI)ADA3580£32.95
- 4 Austin bonnet badge insert (MkI)24G1201£22.96
- 5 Austin Cooper S bonnet badge insert (MkII)ALA6514£13.45
- 6 Austin/Morris Cooper S bonnet badge surround (MkII)ALA6519£14.26
- 7 Austin script boot badge (MkI)14A6802£11.03
- 8 Cooper script boot badge (MkI)24A23£7.61
- 9 Mini script boot badge (MkI)24A997£7.94
- 10 S script boot badge (large)24A1402£6.95
- 11 S script boot badge (small)24A1401£6.95
- 12 1275 script boot badgeALA6696£8.05
- 13 Morris Cooper script boot badge24A24£29.95
- 14 1000 script boot badgeALA6695£10.96
- 15 Cooper S boot badge insert (MkII)ALA6536£12.10
- 16 Austin Cooper boot badge insert (MkII)ALA6537£16.96
- 17 Morris Cooper boot badge insert (MkII)ALA6538£11.15
- 18 Cooper S boot badge surround (MkII)ALA6542£15.25
- 19 'Mk' script boot badge (MkII)AVB191£3.94
- 20 'I' script boot badge (MkII)AVB192£3.80

- 10 S script boot badge (large)24A1402£6.95
- 11 S script boot badge (small)24A1401£6.95
- 12 1275 script boot badgeALA6696£8.05
- 13 Cooper S boot badge insert (MkII)ALA6536£12.10
- 14 Austin Cooper boot badge insert (MkII)ALA6537£16.96
- 15 Morris Cooper boot badge insert (MkII)ALA6538£11.15
- 16 Cooper S boot badge surround (MkII)ALA6542£15.25
- 17 'Mk' script boot badge (MkII)AVB191£3.94
- 18 'I' script boot badge (MkII)AVB192£3.80



Badges (MkIII on)

- 1 Bonnet badge - blue/silverCZH1305£24.95
- 2 Bonnet badge (to VIN 349159) - silver/black CZH4378£25.94
- 3 Mini word bonnet badge (VIN 463577 to 493180) DAB10076£31.96
- 4 Cooper bonnet badgeDAH10036£19.96
- 5 Cooper S boot badge (MkIII)CZH1381£16.30
- 6 Winged Mini boot badge (1997 on)DAH10059MMMM £12.20



Decals for injection Minis

- Mini Cooper rear panel laurel - blackDAF10380PMA£5.62
- Mini Cooper rear panel laurel - whiteDAF10380NMN£5.20
- Side tape - whiteDAE10119NMN£39.95



Cooper bonnet stripes

- No Mini Cooper should be without them, they instantly create that famous Cooper look. These high quality bonnet stripes are available in white.
- Bonnet stripe RH (each) - whiteDAF10402NMN £39.95
 - Bonnet stripe LH (each) - whiteDAF10403NMN £39.95





WAXOYL
moss-europe.co.uk

See the Moss Europe Restoration Tools catalogue or visit moss-europe.co.uk

WAXOYL RUST PROTECTION

Probably the most effective aftermarket rust prevention treatment available. Waxoyl is designed for use in cavities such as sills, chassis leg and wheel arches to provide anti-rust protection. It spreads evenly over the applied surface forming an effective seal against the environment.

Underbody seal is a proven product providing protection to the underbody areas of your car such as wheel arches, inner wings, sills and floors. It can be applied to areas at risk of damage from stones, grit, road salt and water to provide a tough flexible barrier, with added Waxoyl for rust inhibiting. Easily applied by brush, aerosol or using the underbody seal gun.



ELITE STOCKIST
moss-europe.co.uk



Autoglym car care products are renowned for being the best, "the choice" of numerous concours competitors and are approved by leading car manufacturers.

Moss Europe Ltd are proud to be appointed an Elite Stockist by Autoglym, for their range of products see the Moss Europe Restoration Tools catalogue or visit moss-europe.co.uk

Grilles and fittings

The MkI grille is one of the Mini's most striking features. The style of the slats with the moustache surround really shows off the shape of the front end. It was designed to flatter the front and that style was lost with the introduction of the MkII grille assembly. Now you can recreate that look with great ease.

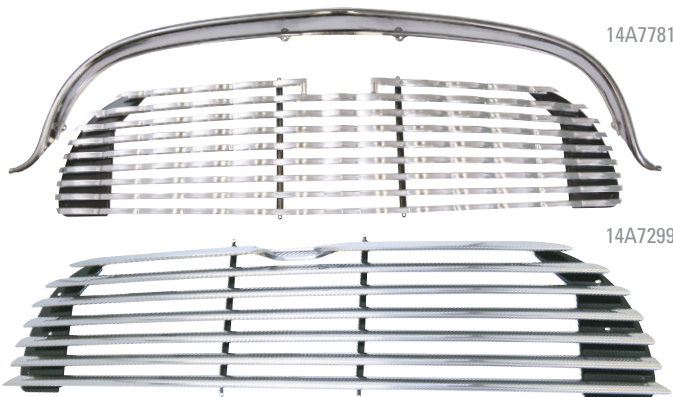

14A7781

14A7299

Grilles (MkI)

24A2158

Austin grille (MkI)	.14A7299	£77.95
Austin Cooper grille (MkI)	.24A198	£89.95
Morris Cooper grille (MkI)	.24A2158	£74.95
Morris Cooper full slat grille internal release (MkI)	.24A2159	£68.95
Moustache grille surround	.14A7781	£79.96
Grille surround fitting kit	.14A7781FK	£3.95
Moustache end piece righthand	.14A7782	£9.25
Moustache end piece lefthand	.14A7783	£9.25
Left and right end mouldings clip	.ADA3583	£0.42

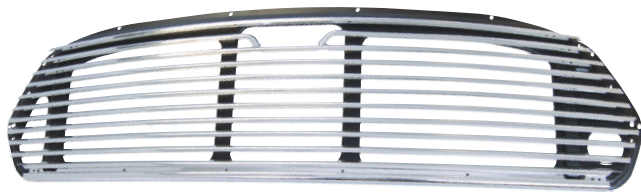

ALA6654Z



DHB10150PME

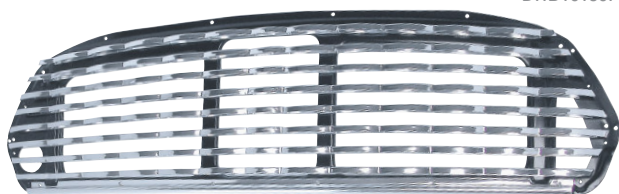

Grilles (MkII on)

8B12508

Chrome grille aftermarket (to 1977 and Mini 30)	.ALA6654Z	£53.95
Black grille (1976-82)	.DHB10150PME	£79.96
Cooper grille (Cooper 1300 + SE)	.ALA6668	£54.80
Cooper grille internal release (Cooper MkII)	.ALA6669	£54.95
Cooper s/s grille external release (Cooper MkII)	.8B12504	£62.95
Cooper s/s grille internal release (Cooper MkII)	.8B12505	£62.95
Austin wavy s/s grille external release (MkII)	.8B12507	£67.96
Austin wavy s/s grille internal release (MkII)	.8B12508	£67.96

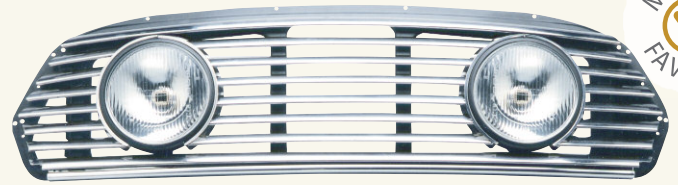

GAC8420X

Grilles with integrated lamp kit (MkII on)

As an alternative to spot lamps bolted in front of the grille, we offer this Cooper MkII style of grille with the spot lamps recessed into the grille itself. Available in a complete kit or separately with internal and external bonnet release. The spot lamps are also available separately just in case you need to replace one.

Grille with spot lamp kit inc. 8B12502 (to 1992)	.GAC8434X	£117.95
Grille with spot lamp kit inc. 8B12503 (1992 on)	.GAC8420X	£109.96

Cooper stainless steel grille (Cooper MkII)8B12502	£87.95
(With 6" holes for spot lamp fitment, external bonnet release access).				
Cooper stainless steel grille (Cooper MkII)8B12503	£83.95
(With 6" holes for spot lamp fitment, internal bonnet release access).				

Spot lamp for grille 8B12502 and 8B12503 (each)	.RL020	£25.96
---	--------	------	--------

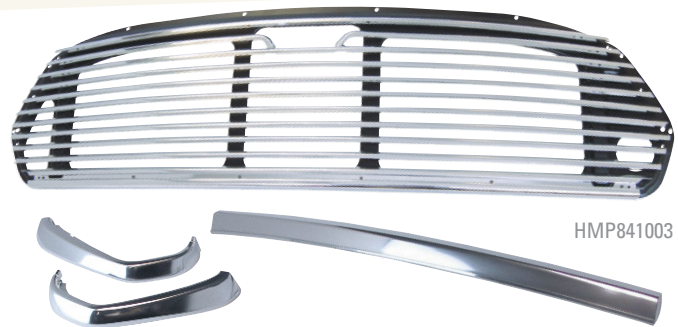

HMP841003

"The grille is one of the Mini's most striking features"

Grille kit (MkIII-IV)

This kit is based on the MkIII and MkIV grille (ALA6654Z) it also contains the grille finisher set (HMP841009).

Grille kit (MkIII-IV)HMP841003	£96.95
-----------------------	------	------------	------	--------

Cooper grille kit

This kit comprises of a Cooper grille (ALA6669) and the grille finisher set (HMP841009).

Cooper grille kitHMP841002	£96.95
-------------------	------	------------	------	--------



Grille finisher kit

Supplied as a set of 3 mouldings, 1 bonnet and 2 side finishers.

Grille finisher kitHMP841009	£38.95
---------------------	------	------------	------	--------



Grille buttons

Grille buttons allow easy access to the engine by replacing the dozen or so self tapping screws which are used to hold the grille in place.

Grille buttons (pair)GAC8421X	£8.60
-----------------------	------	-----------	------	-------





Burr walnut handles

You have the burr walnut dashboard, so why not complete the luxury look with one or all of the following, window winder and door opening handles, suitable for cars from 1969 on, and for 1983 on cars, interior door pulls. Finish the interior off with a matching gear knob.

- Window regulator handles (1969 on)WPA9042X . . .£74.95
- Door release handles (1969 on)WPA9040X . . .£65.95
- Door pulls (1983 on)WPA9041X . . .£64.96
- Gear knob - plainWPA9047X . . .£25.96



Burr walnut dash fascias

In 1989 the Smith gauge binnacle was replaced by units manufactured by Nippon Sieki. We can offer fascias for both types of gauge binnacle. Listed below are a range of dashboard assemblies for Nippon Sieki gauges, on which we can also offer an option of chrome rings around the gauge aperture for the 3 gauge binnacle assembly. For pre 1989 models, at present we can only offer the centre binnacle 3 gauge dashboard.

Centre binnacle

- Dash fascia 3 gauge centre binnacleWPA9012X . .£142.96
- Dash fascia 3 gauge centre binnacle (1 piece) . . .WPA9012XB £142.96



Note: Burr walnut is quite dark, being sourced from a naturally growing product, colours can vary. They are carefully matched, but colour variance is possible.

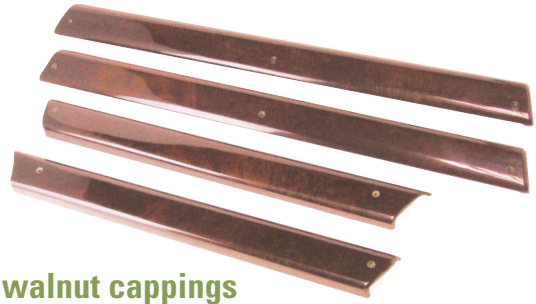

Burr walnut cappings

Many classic coach built Minis were particularly well loved for their opulent interiors. Although we are not able to offer such interior conversions, we can offer a range of high quality Walnut accessories to enhance the interior of your pride and joy. The door capping set contains 4 carefully matched pieces of wood. Suitable for all models.

- Door capping setWPA9017X . .£168.95
- Screw door capping set (10 required)517710£0.25



Offset binnacle with chrome rings

- Dash fascia 2 gauge binnacle RHDWPA9056X . .£142.96
- Dash fascia 2 gauge binnacle LHDWPA9057X . .£142.96
- Dash fascia 3 gauge binnacle RHDWPA9036X . .£142.96
- Dash fascia 3 gauge binnacle LHDWPA9037X . .£142.96

Offset binnacle without chrome rings

- Dash fascia 2 gauge binnacle RHDWPA9013X . .£142.96
- Dash fascia 2 gauge binnacle LHDWPA9014X . .£142.96
- Dash fascia 3 gauge binnacle RHDWPA9015X . .£142.96
- Dash fascia 3 gauge binnacle LHDWPA9016X . .£142.96

Centre consoles

These centre consoles tidy up your interior and also hide the heater motor. See our website for more details.

- Burr walnut with vents & radio (to 1994) RHD .MT9520 . . .£209.95
- Burr walnut with vents & radio (to 1994) LHD .MT9520L . .£188.95
- Burr walnut with vents & radio (1994 on) RHD .MT9521 . . .£219.95
- Burr walnut with vents & radio (1994 on) LHD .MT9521L . .£188.95
- Black vinyl with vents & radio (to 1994) RHD . .MT9524 . . .£109.96
- Black vinyl with vents & radio (to 1994) LHD . .MT9524L . .£102.95
- Black vinyl with vents & radio (1994 on) RHD .MT9525 . . .£109.96
- Black vinyl with vents & radio (1994 on) LHD . .MT9525L . .£102.95

Armrest

No fixing required, this armrest slots between the front seats and includes a storage area over the handbrake, making longer journeys more comfortable.

- Vinyl armrest - blackMT9536 . . .£61.96

Speaker pods

- Front footwell speaker pods 5.25" holes (pair) - black .MT9531 . . .£47.95
- Front footwell speaker pods 6.5" holes (pair) - black . .MT9532 . . .£47.95
- Under rear seat speaker board 6.5" holes - black .MT9534 . . .£47.95
- Under rear seat speaker board 6.9" holes - black .MT9535 . . .£47.95



Keyless entry kit

Our keyless entry kit connects to our central door locking system to facilitate remote locking and unlocking of the doors. A useful security feature is that the unit locks the doors when the ignition is switched on, thereby preventing undesirables getting in. Will only fit Minis from 1976 on and cannot be activated remotely by standard Rover alarm systems.

Keyless entry kitWPA9224X ..£94.96

Note: In some cases only part of the kit is shown.

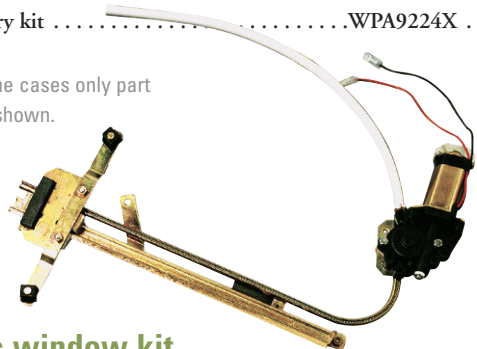

Electric window kit

Electric windows are one of those must have luxury items, so why not the Mini? It just so happens we can help you out. Unlike many other kits on the market, which are basically universal fitting, the Moss kit is custom designed for installation in MkIII and later doors.

The kit includes two new window lift mechanisms complete with motors, two switch pods (which cover the hole where the window winder spindle popped through) and all necessary fittings, wiring and full instructions. One day's labour and you will enjoy the satisfying whir as your windows glide effortlessly up and down.

Electric window kitWPA9220X ..£219.95



Power window module

If you have fitted our electric windows kit and either our keyless entry or alarm system, this neat gadget will close the windows if left open when you arm the system. Cannot be activated remotely by standard Rover alarm systems.

Power window moduleWPA92221X ..£34.96



Footwell light kit

This LED kit allows fitting extra courtesy lamps in your car, ideal for illuminating the footwells. The simple kit can be connected to any 12 volt system and includes two LEDs, wiring harness and instructions.

Footwell light kit 12 volt903-651£28.96



Central locking kit

Central door locking is a key feature of most modern cars, sadly lacking however, on Minis. Our kit has been specifically designed to fit neatly in the door frame without bulging the interior trim of the door skin.

This kit includes fittings hardware and wiring, it can be fitted with the electric window kit. Cannot be activated remotely by standard Rover alarm systems.

Central locking kitWPA9221X ..£99.95



Alarm and immobiliser

Alternatively you can install our alarm kit which has been designed to ease fitment and reduce the amount of cutting and splicing of your car's wiring loom. Only fits Minis from 1976 on and cannot be activated remotely by standard Rover alarm systems.

Specification: 127dB six tone siren, 2 key ring programmable transmitters, triggered by shock and opening of doors, bonnet or boot lid dual zone shock sensor back-up battery starter motor immobiliser.

Alarm and immobiliser kitWPA9222X ..£149.95



Pro start push button

Add a race car feel to starting your classic with the pro start push button. Easy to fit with no cutting of wires required. The LED type illuminates green with the ignition on and goes out when the engine is running.

Pro start push buttonGAC0060£31.96

Pro start push button with LEDGAC0061£41.95



Red start button

This illuminated red start button gives your classic a performance car feel. To prevent theft, your key is still required to switch on the ignition and unlock the steering column. Fitting instructions are included.

Red start button101-180£9.95





GAE125X



GAE130M



GAE130A



GAE124X



GAE129M



GAE127X

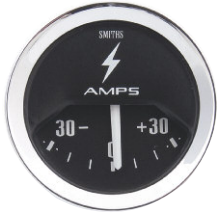

GAE120



GAE122



GAE128X



GAE128M

Auxiliary gauges

Custom build your own dash assembly with these gauges or add them as auxiliary instruments to a wooden dash board. Gauges are supplied with bulb holders and retaining brackets. We offer a range of new gauges in the classic Smiths style with either black or magnolia face with contrasting lettering and an angle section chrome bezel.

Tachometers (80mm diameter)

- 0-7000 tachometer full face 80mm - blackGAE125X . . .£127.96
- 0-8000 tachometer full face 80mm - magnolia . . .GAE130M . . .£145.96
- 0-10000 tachometer full face 80mm - blackGAE130A . . .£145.96

Water temperature & oil pressure gauges (52mm diameter)

- Water temperature °C electric - blackGAE124X . . .£47.95
- Water temperature °C electric - magnoliaGAE124M . . .£47.95
- Thermal transmitter for electric gaugesGTR101£4.96
- Oil pressure psi - blackGAE123X . . .£77.95
- Oil pressure psi - magnoliaGAE123M . . .£79.96
- Oil pressure switch standardGPS133£5.15
- Oil pressure switch early warning (20psi)TT2998 . . .£25.96
- Oil temperature °C - blackGAE129X . . .£53.95
- Oil temperature °C - magnoliaGAE129M . . .£59.95
- Thermal transmitter oil temp negative earth . . .GAE129SENDER .£18.30
- Thermal transmitter oil temp positive earth . . .GAE129SENDERP £15.30

Dual gauges (52mm diameter)

Dual gauges are full face with oil pressure and water temperature shown. These gauges use a capillary transmitter pipe (supplied with Gauge) for



GAE150X



MT9102

water temperature and nylon hose for oil pressure.

- Dual gauge °F & psi - blackGAE127X . . .£132.95
- Dual gauge °C & psi - blackLUSJB100 . . .£86.95

Oil pressure gauge fittings

- Y piece on engine blockLUSIB748£3.95
- Nylon hose for oil pressure gaugeLUSIB703 . . .£12.70

Oil pressure gauge fittings

- Hose for oil pressure gauge, braided stainless steel . .MT9102 . . .£24.95
- Oil hose sealing washer (2 required)2K4936 . . .£0.20

Ammeters & volt meters (52mm diameter)

- Ammeter dynamo models - blackGAE120 . . .£45.95
- Ammeter alternator models - blackGAE121 . . .£45.95
- Voltmeter - blackGAE122 . . .£46.96
- Voltmeter - magnoliaGAE122M . . .£45.95

Time clocks (52mm diameter)

- Clock - blackGAE128X . . .£83.95
- Clock - magnoliaGAE128M . . .£76.96

Lucas auxiliary gauges (52mm diameter)

- Water temperature gauge full face capillaryLUSIB422 . . .£90.95

Boost gauges (52mm diameter)

- Boost gauge -15 to +30 psi - blackGAE150X . . .£89.95
- Boost gauge -15 to +30 psi - magnoliaGAE150M . . .£89.95



GAC8460X
(Gauge not inc.)



GAC8461X

Gauge mounting pods and plinths

A neat way to fit these gauges into your car. The gauge plinths are pressed steel finished with a crackle finished paint.

- Gauge plinth for tachometer onlyGAC8460X . . .£7.66
- Gauge plinth for tachometer & single gaugeGAC8461X . . .£9.65
- Gauge plinth for single gaugeGAC8468X . . .£8.30

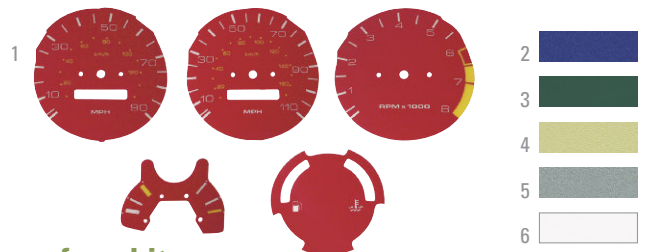

Gauge face kits

These coloured replacement dial faces fit Nippon Seiki gauges fitted to 1989 on models. Contains a full set of faces including the tachometer.

- 1 Gauge face kit - redMT9501R . . .£24.46
- 2 Gauge face kit - blueMT9501B . . .£24.46
- 3 Gauge face kit - greenMT9501G . . .£24.46
- 4 Gauge face kit - magnoliaMT9501M . . .£24.46
- 5 Gauge face kit - silverMT9501S . . .£24.46
- 6 Gauge face kit - whiteMT9501W . . .£24.46



Binnacle kit and gauges

The centre binnacle is essential to any retro conversion. Our kit contains everything you will need to convert to the centre binnacle layout, including binnacle, finisher moulding, wiring harness, dash liners and parcel shelf liner and hardware. The kit is available with the option of either black or magnolia gauges. Note: The speedo is calibrated for Cooper models and may require re-calibrating to suit your car.

- Centre binnacle kit - black gaugesGAC8453X ..£406.96
- Centre binnacle kit - magnolia gaugesGAC8453M ..£406.96

Binnacle components and gauges are also available separately

- 3 clock centre binnacle24A2702£29.50
- Binnacle finisher moulding14A9907£22.40
- Trim to binnacle clip (14 required)14A9796£1.44
- Loom conversion centre binnacleAN133D£23.95
- 130mph speedo Cooper S - black13H4442 ..£166.96
- 130mph speedo Cooper S - magnolia13H4442M ..£176.95
- 200kph speedo Cooper S - black13H4444 ..£166.96
- 200kph speedo Cooper S - magnolia13H4444M ..£159.95
- Oil pressure - black13H4459£59.95
- Oil pressure - magnolia13H4459W ..£63.95
- Water temperature - black13H4460£44.95
- Water temperature - magnolia13H4460W ..£42.95

Handbrake grip



Smarten up the Mini's handbrake. It will make handbrake turns even more fun.

- Handbrake gripFAM8356£7.15



Chrome air vent cover set

This chrome air vent set looks great and adds a touch of style, it includes vent surrounds and adjuster knob covers.

- Chrome air vent cover setMT9301£8.12



Stainless steel mirror

Replace the Mini's standard 'bulky' plastic rear view mirror with this beautifully made stainless steel mirror. It's sleek design is not only a joy to look at but also a joy to use.

- Stainless steel rear view mirrorMT9141£22.98



Chrome interior handle set

Enhance the appearance of your Mini with these chrome plated interior handles. The set features alternative styles of handle and includes chrome plated fixing screws, where necessary.

- Chrome interior handle set (to 1982)WPA9018X ..£68.95



Alloy interior door handle set

A stylish way to enhance your Mini's interior, supplied as a complete set with window winders, door release handles and door pulls.

- Alloy interior door handle setGAC4605£54.95



Chrome ashtrays

Ashtrays were fitted to the fascia and in the rear compartments. We offer the original slotted type, or the later flat type.

- Chrome ashtray slotted lid8D2490£11.95
- Chrome ashtray flat lid24A1538£11.20



Seat belts and harnesses



All the belts and harnesses we supply are manufactured in the UK to exacting standards. The replacement belts and harness kits are sold individually. Harnesses do not contain shoulder pads, these must be purchased separately.



Static front seat belts

- Static seat belt kit - blackSBS300/30£23.95
- Static seat belt kit - redSBS300/30RED ..£35.70

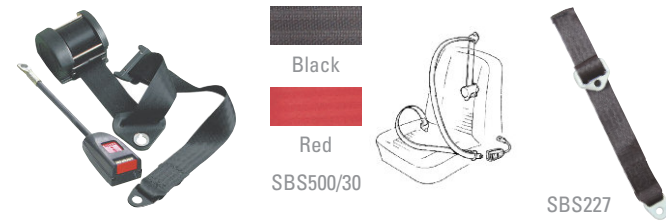

Automatic front seat belts

- Automatic seat belt kit - blackSBS500/30£40.96
- Automatic seat belt kit - redSBS500/30RED ..£63.95

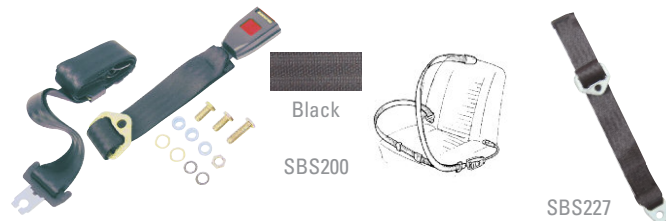

Static rear seat belts

- Static 3 point seat beltSBS200£23.45



- Static lap seat belt - blackSBS210£17.95
- Static lap seat belt - redSBS210RED£36.46
- Static lap seat belt - greySBS210GREY ...£36.70

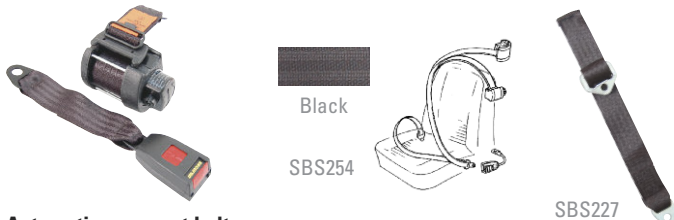

Automatic rear seat belts

- Automatic 3 point seat belt - blackSBS254£47.95

Seat belt extender

This can be used to safely extend the seat belt if required. It should only be bolted to the sill mounting position and then bolted to the eyelet on the end of the seat belt. It must not be used at any other mounting point. 'E' approved for road use. (Image above).

- Seat belt extender - blackSBS227£8.26



Harness kits for road use - 'E' approved

These belts feature 2" webbing with bolt through plate mountings (use with bolts TT7969). Fully adjustable lap and shoulder straps with compact buckle catch. 'E' approved for road use.

- 3 point harness kit - blackSBH628BLACK ..£33.65
- 3 point harness kit - redSBH628RED£33.65
- 4 point harness kit - blackSBH629BLACK ..£29.15
- 4 point harness kit - redSBH629RED£29.15



These belts feature 2" webbing with clip-in snap hook mountings (use with eye bolts TT7967). Fully adjustable lap and shoulder straps with load spreaders on lap belts and a compact buckle catch. 'E' approved for road use.

- 3 point harness kit - blackSBH605BLACK ..£39.80
- 3 point harness kit - redSBH605RED£39.80
- 3 point harness kit - blueSBH605BLUE ...£39.80
- 4 point harness kit - blackSBH655BLACK ..£45.85
- 4 point harness kit - redSBH655RED£45.85
- 4 point harness kit - blueSBH655BLUE ...£45.85



Harness kits for competition use - FIA approved

These harnesses feature 3" webbing with clip-in snap hook mountings (use with eye bolts TT7967). Fully adjustable lap and shoulder straps with a turn lever buckle. Approved for International (RAC/MSA/FIA) and National motorsport use. Not 'E' approved for road use.

- 4 point harness kit - blackSBH693BLACK ..£117.95
- 4 point harness kit - redSBH693RED ...£117.95
- Crotch strap kit - redTT7966£19.96



SBH700BLACK

Retractor reel 3 point harness

This 3 point harness features a retractor reel on the over-shoulder strap allowing movement within the seat. The reel works in the same way as a standard automatic belt engaging the locking mechanism if required.

3 point retractor harness - blackSBH700BLACK **£51.00**

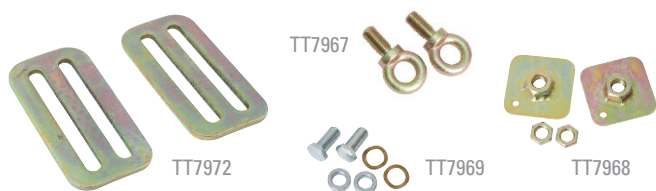

Seat harnesses fittings

- Harness back strap adapter (pair)TT7972**£5.95**
- Eye bolts (pair) use with clip-in mountingsTT7967**£7.15**
- Bolt & spacer (pair) use with plate mountingsTT7969**£4.50**
- Nut plates (pair) reinforced for fixing boltsTT7968**£6.16**



Throttle pedals

Whether you choose the Paddy Hopkirk or plain extension pedal is up to you, they are both specifically designed to aid heel and toe shifting.

- Paddy Hopkirk pedal extension900-315**£32.95**
- Throttle pedal extensionGAC8428X**£6.07**



Bonnet release kit

As fitted to the very latest range of Minis, we have the cable operated bonnet release kit.

Cable bonnet release kitGAC8425X**£22.96**



Steering column drop bracket

This drop bracket lowers the angle of the steering column for a more comfortable driving position, especially when the seat is lowered or moved.

Steering column drop bracket (non airbag to 1996) . .GAC8426X**£4.96**

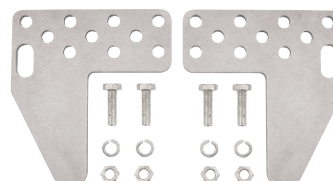

Seat runner extension

Specially for the taller Mini driver, just because you are tall doesn't mean you can't drive your Mini in comfort.

Seat runner extension (pair)GAC8427X**£4.96**



12 volt cigar lighter

This 12 volt supply or cigar lighter is a useful addition to your classic's interior. It is suitable for use as a 12V power socket for in-car accessories such as Sat Nav or simply for lighting your cigars.

- Cigar lighterAHH7010**£16.55**
- Bracket under dash mountingAHH7010BKT**£3.20**



Tax disc holders

Every Mini needs one, choose a classic tax disc holder with the BMC rosette or...

- Plastic BMC rosette tax disc holderCRLH402**£4.55**
- Classic design stainless steel tax disc holder makes it easy to change the disc when you need he replace the old disc. The suction fitting make it easy to use and offers a very nice retro look!
- Tax disc holder stainless steel suction fittingMT5111**£12.50**

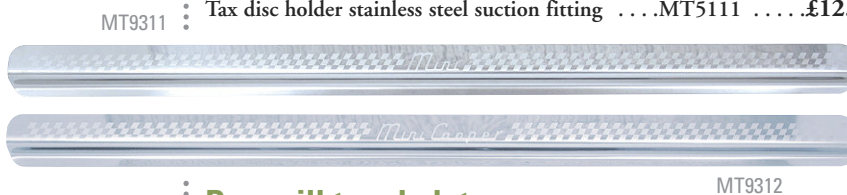

MT9312

Door sill tread plates

Protect the door step as you get in and out with these highly polished stainless steel tread plates. Available in two designs these sill plates also are easy to fit.

- Stainless steel with Mini and chequered textMT9311**£25.50**
- Stainless steel with Mini Cooper & chequered text . .MT9312**£25.50**



Moto-Lita steering wheels

Moto-Lita

Moto-Lita are among the finest replacement steering wheels available. Designed to enhance the appearance of the cockpit and provide an improved feel for the driver. Available in a variety of styles, materials and sizes to suit, please see our website for the full list of options. All steering wheels listed feature drilled spokes, except where detailed.

Wood rimmed steering wheels

- Mk3 flat polished spokes 13"MLW1115-13 ..£152.95
- Mk3 flat polished spokes 14"MLW1115-14 ..£152.95
- Mk3 flat polished spokes 15"MLW1115-15 ..£152.95

- Mk3 dished polished spokes 13"MLW1116-13 ..£152.95
- Mk3 dished polished spokes 14"MLW1116-14 ..£152.95
- Mk3 dished polished spokes 15"MLW1116-15 ..£152.95

- Mk3 flat polished spokes with thin slot 14" ..MLW1120-14 ..£152.95
- Mk3 flat polished spokes with thin slot 15" ..MLW1120-15 ..£152.95
- Mk3 flat polished spokes with wide slot 15" ..MLW1122-15 ..£152.95

Leather trimmed steering wheels

- Mk4 flat polished spokes 12"MLW1111-12 ..£152.95
- Mk4 flat polished spokes 13"MLW1111-13 ..£152.95
- Mk4 flat polished spokes 14"MLW1111-14 ..£152.95
- Mk4 flat polished spokes 15"MLW1111-15 ..£152.95

- Mk4 flat black spokes 13"MLW1112-13 ..£152.95
- Mk4 flat black spokes 14"MLW1112-14 ..£152.95
- Mk4 flat black spokes 15"MLW1112-15 ..£152.95

- Mk4 dished polished spokes 13"MLW1113-13 ..£152.95
- Mk4 dished polished spokes 14"MLW1113-14 ..£152.95
- Mk4 dished polished spokes 15"MLW1113-15 ..£152.95

- Mk4 dished black spokes 13"MLW1114-13 ..£152.95
- Mk4 dished black spokes 14"MLW1114-14 ..£152.95
- Mk4 dished black spokes 15"MLW1114-15 ..£152.95

Mahogany rimmed steering wheels

- Mk9 flat polished spokes 14"MLW1119-14H ..£213.95
- Mk9 flat polished spokes 15"MLW1119-15H ..£213.95



Moto-Lita accessories

Moto-Lita

- Billet centre cap 3.5"MLW1117BCC ..£41.95
- Billet horn push 3.5"MLW1117BHP ..£72.95
- Moto-Lita centre capMLW1117X1 ..£10.60
- Centre cap and horn pushMLW1117X2 ..£19.96
- Polished ring kitMLW1117X3 ..£11.26
- Black ring kitMLW1117X3B ..£10.96



Tourist Trophy centre cap

Replace your Moto-Lita centre cap/horn push with one of our Tourist Trophy direct replacements. Featuring a large chrome & enamel marque badge. If your car has the horn push on a stalk please use the Tourist Trophy horn push/centre cap supplied as a centre cap, keeping your existing horn push on the stalk.

- Tourist Trophy centre cap/horn push905-649£16.96

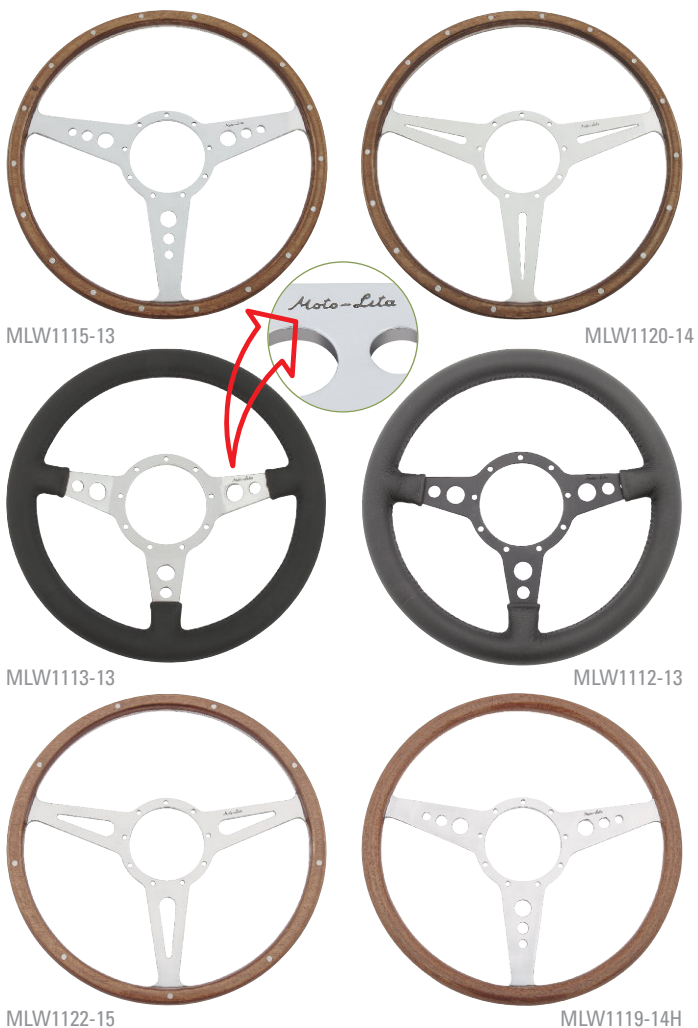

Moto-Lita adaptor bosses

- Moto-Lita horn push for single stalk (1958-66) MLW1117B1HM ..£52.96
 - Moto-Lita non horn push for single stalk (1966-69) .MLW1117B1M ..£52.96
 - Moto-Lita for single stalk (1969-75)MLW111725M ..£52.96
 - Moto-Lita for twin stalk (1976 on*)MLW111745M ..£52.96
- (*Note: On later cars from 1989 on there is only one indicator cancelling pin, match the boss to the existing wheel and remove the unwanted pin).



Gear stick gaiter finisher kit

Smarten up your gear stick with this easy to fit universal gaiter finisher kit. Some gaiters may require modification to fit. (Gaiter not included).

- Chrome gaiter finishing kitGAC9540£16.96

Expandable cup holder

This extremely useful folding cup holder can be mounted almost anywhere inside your car. The arms adjust in or out to suit the size of your container and folds up when not in use to give a neat appearance.

- Expandable cup holder222-090£7.96

MOMO1077



MOMO1078



MOMO1080



MOMO1079



MOMO steering wheels



MOMO have long supplied the racing world with high quality steering wheels, contoured to fit perfectly in the hand. The Prototipo has a retro look that would not look out of place in any Classic Mini.

- MOMO Tuner 350mm - black/anthraciteMOMO1077 **£185.95**
- MOMO Tuner 350mm - black/blackMOMO1078 **£185.95**
- MOMO Prototipo 350mm - black/silverMOMO1079 **£172.96**
- MOMO Prototipo 350mm - black/blackMOMO1080 **£169.96**

Adaptor bosses

- MOMO adaptor boss (1969-76)GAC8491X .. **£57.95**
- MOMO adaptor boss (1976-91)GAC8492X .. **£59.95**
- MOMO adaptor boss (1991-96)GAC8493X .. **£57.95**
- MOMO/Mountney M range adaptor boss (1976-91) .MT9315 **£30.60**



MOMO gear knobs



For over 30 years MOMO has been developing and producing automotive products to the very highest quality. So renowned for their quality that many manufacturers fit MOMO as an optional upgrade. Whichever gear knob you choose, it is sure to complement your interior.

- 1 Race air leather alloy gear knobMOMO1060 **£72.95**
- 2 Race air leather gear knobMOMO1057 **£67.96**
- 3 Anatomic hide gear knobMOMO1050 **£58.96**
- 4 Aluminium sport gear knobMOMO1054 **£54.95**
- 5 Competition gear knobMOMO1053 **£54.95**



Gear knobs

These quality Mini gear knobs are available in leather or wood. Choose from either a Cooper logo, Mini image or the later Mini wing logo.

- 1 Leather Cooper gear knobGAC4052C .. **£11.45**
- 2 Wood Cooper gear knobGAC4053C .. **£10.30**
- 3 Leather Mini gear knobGAC4052X .. **£11.45**
- 4 Wood Mini gear knobGAC4053X .. **£10.85**
- 5 Leather Mini wings gear knobGAC4055X .. **£11.20**
- 6 Wood Mini wings gear knobGAC4054X .. **£10.75**

Dynamat
FOR FULL RANGE
SEE RESTORATION TOOLS
CATALOGUE



Dynamat heat & sound insulation

We now stock Dynamat, a revolutionary range of products designed to keep your classic cool & quiet.

- Non absorbent materials
- Self adhesive 'peel & stick'
- Easily cut & moulded to fit
- Isolates panel vibration
- Reduces road noise
- Reduces heat soak from engine & exhaust

Dynamat Xtreme

A highly efficient, composite material designed to reduce noise, vibration & heat soak through panel work.

- Dynamat Xtreme - speaker packGAC90511 .. **£12.95**
(2 sheets of 254mm x 254mm (10" x 10").
- Dynamat Xtreme - wedge packGAC90512 .. **£24.95**
(1 sheet of 457mm x 812mm (18" x 32").
- Dynamat Xtreme - door packGAC90513 .. **£69.95**
(4 sheets of 305mm x 914mm (12" x 36").
- Dynamat Xtreme - bulk packGAC90514 .. **£179.96**
(9 sheets of 457mm x 812mm (18" x 32").

Dynaliner

Dynaliner is an ultra-light weight, durable single layer insulation material that can be used as an alternative to traditional underfelt. It provides acoustic isolation and excellent thermal insulation.

- Dynaliner - 1/8" thickGAC90531 .. **£40.96**
(1 sheet of 813mm x 1372mm (32" x 54").
- Dynaliner - 1/4" thickGAC90532 .. **£65.95**
(1 sheet of 813mm x 1372mm (32" x 54").
- Dynaliner - 1/2" thickGAC90534 .. **£85.96**
(1 sheet of 813mm x 1372mm (32" x 54").

Hoodliner

Designed specifically for under bonnet insulation, Hoodliner absorbs engine noise to help keep your car quieter. The aluminised skin creates a water & oil barrier that reflects up to 97% of heat to protect the bonnet's paint.

- HoodlinerGAC90541 .. **£69.95**
(1 sheet of 813mm x 1372mm (32" x 54").



Carpet sets

These carpet sets are moulded to follow the contour of the floor pan exactly, to give a quality fit and finish to your car. As any Mini owner is aware it can get very noisy when driving at speed. These carpet sets feature 12mm thick sections of sound deadening laminated to the backing of the carpet to keep the sound levels as low as possible.

These carpet sets include: front wheel arch, front bulkhead, front & rear floor, cross member and sill carpets. Supplied with all fittings and instructions.



CSR9002X

Early carpet sets (to 1973)

To fit MkI-III saloon models with 'magic wand' or remote change gear levers. Carpets are marked with the various hole options on the rear to help position the holes.

- Carpet set - blackCSA9002X ..£161.95
- Carpet set - redCSR9002X ..£161.95
- Carpet set - greyCSF9002X ..£161.95

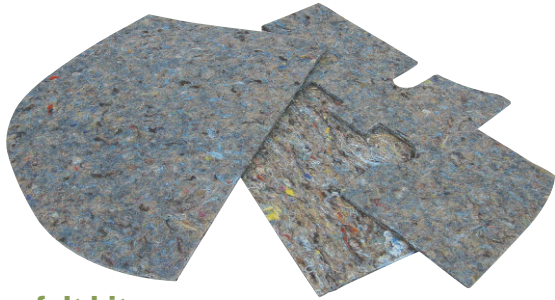

GAC8429X

Under felt kit

Keeping the noise level down is not easy! Most carpet sets on the market don't have a great deal of backing on them so fitting the under felt fit not only reduces the noise level but also make the carpet feel much nicer under foot.

- Under felt kit pre cutMT9540£25.94
- Under carpet sound insulation kitGAC8429X ..£42.95
- Space age heatshield 48" x 72" sheet409-016£29.95



Gear lever gaiter

- Gear lever gaiter - blackGAC8488X ..£41.95
- Chrome gaiter finishing kitGAC9540£16.96



CSF9000X

Late carpet sets (1973 on)

To fit saloon models with rod change gear levers.

- Carpet set - blackCSA9000X ..£161.95
- Carpet set - redCSR9000X ..£161.95
- Carpet Set - greyCSF9000X ..£161.95



CSA9002Z

Budget carpet sets

We can also offer a moulded carpet set produced by the original manufacturer and finished with bound edges. This set does not have sound deadening backing material, but it can be used with the sound deadening kit left.

These carpet sets include: front wheel arch, front bulkhead, front and rear floor and sill carpets. Supplied with all fittings and instructions.

- Carpet set - blackCSA9002Z ..£36.70
- Carpet set - redCSR9002Z ..£36.70
- Carpet set - greyCSF9002Z£36.70
- Carpet set - blueCSN9001Z£39.95



Carpet fittings

- 1 Fastener fitted to floor610624£0.25
- 2 Rivet fastener to floorGHF600£0.05
- 3 Clip on back of carpet2H8445£0.40
- 4 Spike ring through carpet pile14G8736£0.25



EVANS WATERLESS COOLANT

Evans waterless engine coolant is a unique and revolutionary engine coolant fluid formulated to improve efficiency and reduce corrosion of your car's cooling system, protecting your cherished classic.

It neither contains water nor requires mixing with water, overcoming the limitations associated with using water in engine cooling systems, such as boiling and corrosion.

Evans offer a full range of coolant to suit vintage, classic and modern car cooling systems, see the Moss Restoration Tool catalogue or visit moss-europe.co.uk

VINTAGE COOL 180

Vintage Cool should be used on older (pre 1945) engines that have copper, brass & bronze and more porous cast iron components - best suited to MG T-Types etc.

CLASSIC COOL 180

Classic Cool is suitable for all of our later (post 1945) classic cars, such as MGA, MGB's, Spridget's, TR's, Spitfire's and GT6's, Classic Minis, etc.

POWER COOL 180

Power Cool is suitable for all engines with major aluminium components, such as alloy heads or full alloy engines, it is suitable for Rover V8, K Series and Mazda MX-5.

- NO WATER
- NO OVERHEATING
- NO SCALING
- NO PRESSURE
- MORE BHP
- NO LINER PITTING



Protect your investment and provide lifetime cooling!

Headlining

If your headlining is showing signs of old age, then why not replace it? We can supply a ready stitched vinyl replacement main section with all loops stitched in place. The kit also contains a pair of rear pillar covers in matching material.



HLK3012P

Headlining

- Headlining kit (MkI) - crackle finish creamHLK3000C . .£119.95
- Headlining kit (MkIII) - light greyHLK3012P . .£119.95
- Headlining kit (MkIII) - whiteHLK3012W .£119.95

Headlining rails

Headlining rails provide the material with its shape. They are counted from front to back and are also colour coded for identification.

- Headlining rail number 1 - redEEB100060 . .£15.46
- Headlining rail number 2 & 3 - whiteEEB100070 . .£15.46
- Headlining rail number 4 - blackEEB100080 . .£15.46
- Headlining rail number 5 - blueEEB100090 . .£15.46
- Headlining rail number 6 - yellowEEB100100 . .£15.46



GAC8465X

GAC8484X

Sun visors

Made to original standards...

- Sun visor no mirror - blackGAC8465X . .£41.95
- Sun visor with mirror - blackGAC8466X . .£49.96
- Sun visor fitting kitGAC8467 . .£19.94
- Sun visor (1966-69) - creamGAC8484X . .£41.95



BFK9001X

Boot floor kit

Tidy the boot area of your Mini with one of these carpeted wood floors. When installed they provide a flat floor that not only tidies the boot area, but also helps to protect the battery and spare wheel.

- Boot floor kit 5.5 gallon tanks (1974-79)BFK9001X . .£85.94
- Boot floor kit 7.5 gallon tank (1980 on)BFK9002X . .£85.94
- Bracket set (up to 165 section tyres)BFK9004X . .£120.95



SEAT01V

SFX Cobra classic bucket seats

Cobra are one of the world's most renowned manufacturers of sports application seats. The (low back) classic bucket seat is ideal for the Mini, enabling easy access to the rear, while also giving extra side support.

They are essential for creating that retro style interior, and are available in nylon or vinyl. The nylon seat is also available with a headrest. Specification: Weight 4kg, height 56cm, width 51cm, depth 50cm. Please note: To fit the Cobra classic seat you will require a Cobra subframe.

- Low back seat in nylon - blackSEAT01£139.96
- Low back seat with headrest in nylon - black . .SEAT01HR . .£242.95
- Low back seat in vinyl - blackSEAT01V . .£144.95

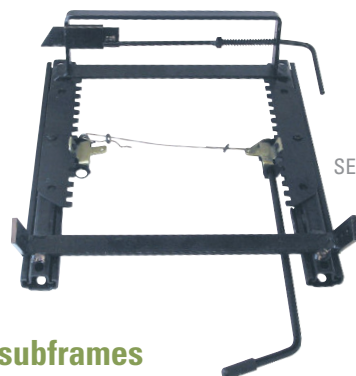

SEAT10RIGHT

Cobra seat subframes

- Subframe without floor catch/lock (to 1976) . .SEAT09£78.95
- Subframe with floor catch/lock LH (1976 on) .SEAT10LEFT . .£66.95
- Subframe with floor catch/lock RH (1976 on) .SEAT10RIGHT £66.95
- Seat runner extensions (pair)GAC8427X . .£4.96

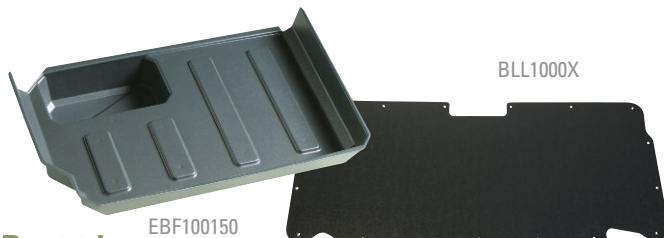

EBF100150

BLL1000X

Boot trim

Tidy the boot area of your Mini with this moulded plastic boot floor liner (not suitable for injected or twin tank cars). Also the boot lid liner really smartens thing up and stops those washers falling into the boot frame never to be seen again.

- Boot lid liner (inc. screws)BLL1000X . .£25.94
- Plastic boot floor linerEBF100150 . .£36.95



Footwell mats

Protect the carpets in your Mini with these quality overmats from British Motor Heritage with bound edges and an embroidered Mini logo. The tailored fit and non slip backing ensures secure location. Available as two or four piece sets. Also available without logos.

- Footwell mats with logo (set of 2) (1973 on) ... GAC6902 ... £45.95
- Footwell mats with logo (set of 4) (1973 on) ... GAC6904 ... £87.95
- Footwell mats no logo RHD (set of 4) ... MFM113 ... £31.60



Dash liner kits

Supplied in black these liner kits improve the appearance of the dash area.

- Central speedo panel kit (speedo in centre) ... DPK9000X ... £40.96
- Centre binnacle panel kit (3 gauges no vents) ... DPK9001X ... £40.96
- Centre binnacle panel kit (3 gauges with vents) ... DPK9002X ... £40.96
- Offset binnacle panel kit (2 & 3 gauge) RHD ... DPK9003X ... £61.96
- Offset binnacle panel kit (2 & 3 gauge) LHD ... DPK9004X ... £61.96
- Parcel shelf liner kit (all models) ... DPK9010X ... £39.95

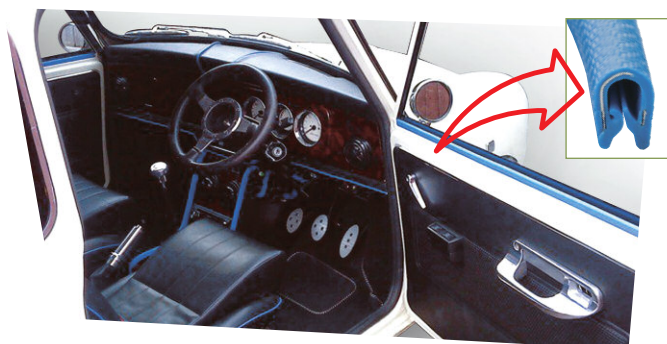

Edge trim finisher

Flexible herringbone pattern edge trim finisher. U section PVC with sprung steel inner. Will grip onto 0.5mm - 3mm thick edge. Available in four different colours with many different uses. Seen here is some the blue edge trim on the inner window seal and around the centre console...the usages are endless.

- Edge trim finisher - black ... 624801M ... £3.25
- Edge trim finisher - blue ... 624801MB ... £11.26
- Edge trim finisher - red ... 624801MR ... £11.26
- Edge trim finisher - white ... 624801MW ... £11.26

Trim panel kits

Designed to enhance the interior of your Mini, available in black, red or grey (nimbus). These high quality trim panel kits feature a horizontal seam welded design styled on the original Cooper interior trim design. The deluxe kit features a foam backing to the vinyl panels to give a more padded feel.



MkI & MkII Deluxe trim panel kits

- Deluxe trim panel kit - red ... TKR9000X ... £328.94
- Deluxe trim panel kit - grey ... TKF9000X ... £354.95

MkI & MkII Standard trim panel kits

- Standard trim panel kit - black ... TKA9008X ... £317.95
- Standard trim panel kit - grey ... TKF9008X ... £317.95



MkIII Monte Carlo trim panel kits

- Monte Carlo trim panel kit - black ... TKA9042X ... £197.95
- Monte Carlo trim panel kit - red ... TKR9042X ... £197.95
- Monte Carlo trim panel kit - grey ... TKF9042X ... £197.95
- Clip door trim boards (18 per car) ... GHF1222 ... £0.30
- Door pocket ... YGA452 ... £15.95



Door cards only

- Door card wind up window (1976-80) - black ... DP3048 ... £75.95
- Door card painted (MkI-II) - black ... TKA9010X ... £40.24
- Door card padded (MkI-II) - black ... TKA9011X ... £66.95

Door pocket finisher

For MkI-II models this finisher tidies up the edge of the door pocket.

- Door pocket finisher (MkI-II) ... 24A1169 ... £13.70
- Clip (4 per trim) ... EYC10048 ... £1.96





RetroSound radios

The RetroSound range of radio & MP3 players maintain the original 'twin knob' (DIN-D) style mounting required for many classic cars. Music can be played from external sources such as iPods, USB flash drives & SD cards, all connected out of sight.

Model 2

The stylish new Model 2 range offers a high spec radio that gives that classic look with modern digital music capabilities. The Model 2 features iPod and iPhone charge and play operation as well as Bluetooth connectivity with hands free calls. Also includes a daylight compatible wide angle LCD colour display.

- Rear mounted USB & mini jack inputs
- RDS FM capable tuner - AM/FM PLL tuner with 30 presets
- 25W x 4 (RMS) integrated amplifier
- Pre-amp RCA outputs – with fade and balance
- Versatile "InfiniMount" adjustable shaft/bracket system
- Display shows track names, RDS data or clock
- Separate power amp and aerial switching leads
- 2 year manufacturer's warranty

RetroSound Model 2 - chrome230-380£279.95
RetroSound Model 2 - black230-385£279.95

Zuma

The Zuma radio features retro-styled buttons, a wide high resolution LCD screen with green/white display & fascia design giving a more classic look to the unit. The Zuma radio includes many of the same features as the Model 2 radio, excluding the iPod and iPhone capabilities and Bluetooth connectivity.

RetroSound Zuma - chrome230-317£198.95
RetroSound Zuma - black230-322£198.95

Classic Sound

The Classic Sound is an entry level unit with lower specifications. It features a different fascia design and only has a front mounted mini-jack input and AM/FM radio.

RetroSound Classic Sound - chrome230-324£159.95
-----------------------------------	--------------	-------------

Fitment note: The car must be negative earth. Units supplied without faceplate or knobs. Please check website for full range and spec.

Faceplate and knob kits

For the full range of faceplates and kits, please see our website.

F&K kit - all chrome230-326£27.95
F&K kit - all black230-327£27.95
F&K kit - black/chrome230-329£27.95
F&K kit - black/chrome edge & black230-328£27.95
F&K kit - black/chrome edge & black/chrome230-334£27.95
F&K kit - Becker pinstripe230-341£27.95
Knob set only - chrome230-331£14.95
Knob set only - black230-332£14.95

RetroMod speakers by RetroSound

The RetroMod range of speakers from RetroSound has been designed to compliment their range of Classic radios and have been manufactured to meet the demands of modern high performance amplifiers.

Dual voice coils (DVC) speakers

This system allows for 2 stereo channels (left & right) to be connected to the same single speaker. This means that originality can be maintained on cars where a single speaker was fitted in the centre of the dash or rear shelf. These speakers are supplied individually without mesh grilles, to fit existing mountings.

6.5" dia 3 way, DVC, no grilles (each)230-505£49.96
5" x 7" 3 way, DVC, no grilles (each)230-545£58.96
6" x 9" 3 way, DVC, no grilles (each)230-510£43.96

Single voice coils (SVC) speakers

The SVC range of speakers is a standard configuration single channel speaker for normal installations (left & right mounted speakers, such as doors or dash). These speakers are available in a range of sizes and specifications. Full details available on our website.

3.5" dia 2 way, 20W max, no grilles (pair)230-515£36.95
4.5" dia 2 way, 40W max, with grilles (pair)230-535£68.95
5.25" dia 2 way, 80W max, no grilles (pair)230-520£50.95
4" x 6" 2 way, 80W max, flame bezels (pair)230-525£41.95
5" x 7" 3 way, 60W max, with grilles (pair)230-540£62.95
6" x 9" 3 way, 100W max, with grilles (pair)230-530£63.95
6" x 9" 3 way, 100W max, with grilles (pair)230-531£139.96

RetroMod 8" Subwoofer

The compact design and powerful bass response make this ideal for under seat mounting and numerous other in-car applications. The rigid die cast aluminium chassis and powerful Class D amplifier allows this sub to reproduce low frequencies down to 35Hz.

8" Subwoofer with internal amplifier230-550£170.96
--------------------------------------	--------------	-------------

Radio aerials

Our range of aerials offers a variety of fitting options from wing to roof mountings. The wing mount aerial features adjustable bases to compensate for slight angles off horizontal. The roof mounted aerial features a removable stainless steel mast with a chrome base plate. Aerial extension cable is also available.

Hide-away amplified aerial230-555£19.96
Aerial wing mount manualMRA001£7.45
Aerial wing mount electricAJM1112X£42.95
Aerial roof mountEEP11Z£11.56
Extension lead aerial 3 metreZKC533£8.95



This hide-away amplified aerial can be mounted hidden away, almost anywhere inside the car. Ideal if you don't want to install a wing or roof aerial to keep your classic original.



Classic Mini T-shirt

These stylish new navy blue T-shirts, with contrasting white rib collar and cuff, feature a silk screen printed profile image of a Classic Mini and Mini logo. Made from 100% cotton they include a white roundel and racing number on the back. For other models, please visit our website. Available in sizes S (35/37"), M (38/40"), L (41/43"), XL (44/46") & XXL (47/49").

- Classic Mini navy blue/white T-shirt - smallGAC44801 . . .£12.95
- Classic Mini navy blue/white T-shirt - medium . .GAC44802 . . .£12.95
- Classic Mini navy blue/white T-shirt - largeGAC44803 . . .£12.95
- Classic Mini navy blue/white T-shirt - X-large . .GAC44804 . . .£12.95
- Classic Mini navy blue/white T-shirt - XX-large .GAC44805 . . .£12.95

Camber gauge



Setting the camber of your car's suspension is essential to get the handling and steering correct. This gauge is an inexpensive way to check camber between positive 3° and negative 3° of camber. The magnetic base fixes to the brake disc or hub face.

- Camber gaugeMTR4201 . . .£28.96

Switch bezel tool



The round bezels on most Lucas switches have two slots, and nobody has the special tool - a bezel nut spanner - you need to take them off. The set includes tools for 0.75" diameter and 1" diameter bezel nuts and saves you using screwdrivers and other assorted sharp implements that result in scratched dashboards.

- Switch bezel tool384-960 . . .£17.95

Flywheel puller



The only way to remove Mini flywheels. The drop forged puller is suitable for use on diaphragm or Verto clutches.

- Classic Mini flywheel pullerDMR19862 . . .£30.05

Suspension cone compressor



These cone compressors are a must for changing rubber suspension cones or working on the front suspension of your Mini. **Note: The new cones (Part No. FAM3968) have a metric thread.**

- Cone compressor metric cones onlyMT9600 . . .£26.95
- Cone compressor metric & imperial conesGAC9424X . . .£58.96



Thermal mugs

Our stylish new range of thermal mugs will maintain your drinks temperature whether hot or cold. Desk mugs feature a wider design with handle. Travel mugs are a slimmer design to suit most in-car cup holders. Both types feature a non-slip base and a removable cap.

- Travel mug - Union Jack230-946 . . .£11.95
- Desk mug - Union Jack230-947 . . .£11.95

Patches



Show your allegiance with one, or all of these quality sew-on patches. We also have a selection of iron-on patches available.

- 1 Union flag sew-on patch229-510 . . .£2.35
- 2 Mini logo sew-on patchGAC4128X . . .£2.30
- 3 Mini winged logo sew-on patchGAC4051 . . .£3.40
- 4 Mini Cooper sew-on patchGAC4052 . . .£3.55
- 5 British Leyland sew-on patchGAC9960X . . .£3.60
- 6 BMC sew-on patchGAC9961X . . .£3.60
- 7 Mini iron-on patch - redGAC6080X . . .£2.65
- 8 Mini iron-on patch - blackGAC6081X . . .£2.65
- Mini iron-on patch - blueGAC6082X . . .£2.65
- Mini iron-on patch - greenGAC6083X . . .£2.65



Key fobs

These traditional leather key fobs look good and keep your keys together.

- 1 Union flag key fobGAC4042 . . .£4.40
- 2 BMC rosette key fobCRSP401 . . .£4.40
- 3 Leyland Mini key fobGAC4043 . . .£4.40
- 4 Mini Cooper key fobGAC4044 . . .£4.40



Outdoor car cover

This waterproof outdoor cover is suitable for medium to long term storage. Manufactured from frost and UV resistant grey vinyl, with a soft cotton inner lining. Welded seams eliminate water penetration whilst a fitted air vent minimises moisture build-up between cover and body. Front and rear hems are elasticated and there are rubber bungies for attaching to the wheels. Supplied in a zipped handled bag. **Must be used on a dry car.**

- Outdoor car coverGAC9503 . . .£170.95





facebook.com/mosseurope

Share your news & photographs with other classic enthusiasts and keep up to date with whats happening at Moss



twitter.com/mosseurope

SHARE NEWS, OFFERS & CHATTER



The Moss **e**bay store is growing...

stores.ebay.co.uk/moss-europe-ltd

- 1,000s of Parts, Accessories & Tools
- New product added regularly
- Easy payment with PayPal



moss-europe.co.uk
keeping the great marques alive

DO YOU NEED A...

Whatchamacallit, Thingamajig or Oojamaflip?

...MOSS CAN HELP*



*Moss Europe don't actually sell Whatchamacallits, Thingamajigs or even Oojamaflips, but we do stock tens of thousands of parts for British Classics



The ideal gift for any classic car enthusiast

AVAILABLE IN £10, £25 & £50 DENOMINATIONS

Order by phone, in branch or at moss-europe.co.uk



Books, manuals & DVDs

Our range of publications have been put together after hours of bedtime reading, to bring you a selection of books about the restoring and working on classics that will enlighten the reader. Beware, some of these books may cause you to damage the contents of your wallets and purses in a big way.

We stock the ever popular Haynes range of manuals, these manuals are essential equipment for the home mechanic. While the carburettor and component manuals contain more details than the general workshop manuals. Of course there are also the modification and tuning guides a must for the Mini enthusiast.

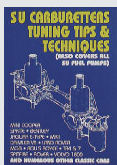

Tuning SU carburettors

This book looks into the basic design of the SU carburettor. It covers many areas including overhaul, tuning mixtures, jet and needle identifications and SU fuel pumps.

Tuning SU carburettorsMGL0070£13.95



SU workshop manual

Factory manual covering both carburettors and fuel pumps.

SU workshop manualGAC1044X . . .£19.95

SU needle chart

The chart identifies the correct replacement SU needle when modifications have been carried out to the engine or induction.

SU needle chartALT9501 . . .£11.90

SU parts catalogueALT9524 . . .£12.95

Carburettor manual

This Haynes 'techbook' manual covers SU, Stromberg, Weber and Dellorto carburettors. Giving an insight into the way carburettors operate and how to maintain and tune them, as well as including detailed servicing and overhaul procedures.

Carburettor manualMGL0279 . . .£28.95

SU carburettor rebuild DVD

This 2 hour, 40 minute film explains how to rebuild SU carbs.

SU carburettor rebuild DVD . . .211-036 . . .£29.95

Weber carbs: Tuning tips & techniques, by John Passini

This book is the distillation of many years experience of working with Weber carbs. The mysteries of why and how they work and the practicalities of getting the best from them. Also setting-up, fault-finding, maintenance & repair are all covered.

Tuning tips & techniques213-431 . . .£9.94

Lucas fault diagnosis manual

This guide presents a logical sequence of tests that may be carried out on starters, generators, regulators, ignition and

lighting systems. Written for technicians, this book can be easily understood by the amateur mechanic.

Lucas fault diagnosis manual . . .GAC1029X . . .£3.65

Classic car bodywork, by Martin Thaddeus

A book written for the home restorer who, until now, lacked the confidence to tackle bodywork. With specially devised techniques which don't rely on workshop plant, this work spans the gap between professional and amateur.

Classic car bodyworkMGL0330 . . .£27.50

Car bodywork, by Lindsay Porter

Here is the complete practical guide to car bodywork repair and renovation for the DIY enthusiast. With the aid of detailed illustrated, step-by-step instructions the manual explains how to tackle a wide range of jobs.

Car bodywork repair manual . . .MGL0335 . . .£20.99

Classic car interior restoration, by Kim Henson

This well illustrated book provides the tricks of the trade to enable the interior of a car of any age to be successfully renovated. It includes cleaning and restoration techniques; a good guide for the enthusiast restorer.

Classic car interior restoration . .MGL0336 . . .£21.99

Haynes restoration manual

Restoration manualMGL0265 . . .£21.99

Haynes workshop manuals

Workshop manual (1959-69) . . .MGL6219X . . .£25.00

Workshop manual (1969-01) . . .MGL6220X . . .£21.99

Tuning guide by David Vizard

Tuning BL's "A" series engine . . .MGL0063 . . .£25.00

Original series book - Mini Cooper, by John Parnell

This book is the definitive guide to one of Britain's best-loved sports car, the 'Original' series books are indispensable for all owners, restorers, buyers and enthusiasts.

Original series bookMGL0254 . . .£27.50

Original Technical Publications Heritage DVD

Original Technical Publications for heritage cars have now carefully reproduced a range of DVD's using historical archives. Extensive research has allowed access to original Heritage publications needed to maintain your classic.

Now owners and enthusiasts can have easy access to original publications, including parts catalogues, service manuals and owner's literature.

OTP DVD, Mini (1959-00) . . .HTP2006 . . .£34.96

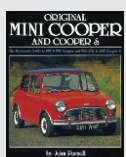
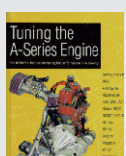
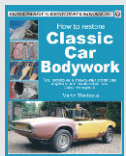

Union flag

Lightweight polyester with metal grommets on the hoist.

Union flag -36" x 60"GAC9939X . . .£18.95



Union flag mouse mat

This mouse mat is the perfect companion for your computer.

Union flag mouse matGAC1045X . . .£8.35



Carburettor models

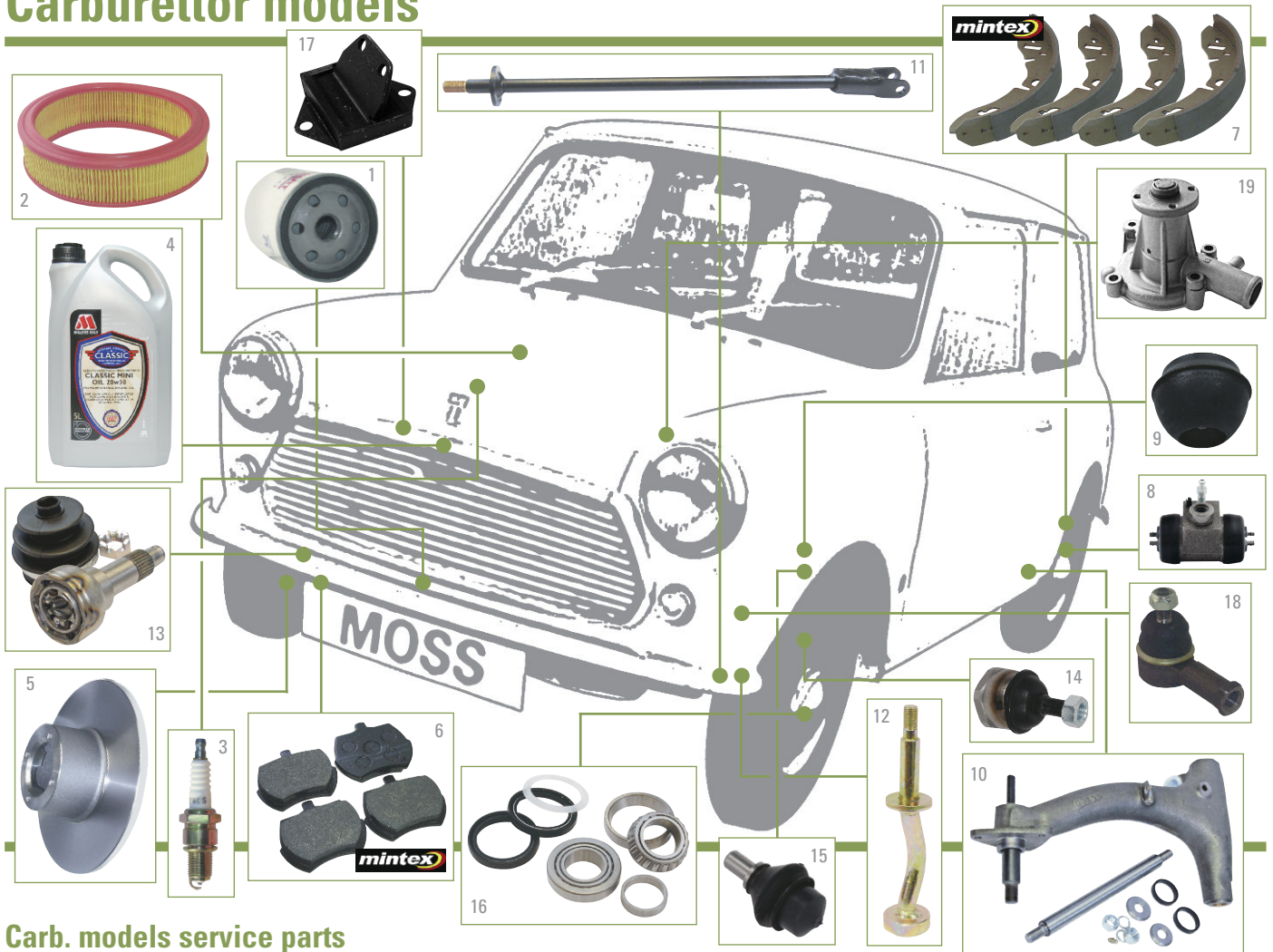

Carb. models service parts

Old school carb Minis are still very popular with Mini owners. By far the easiest model to service there really are no excuses for neglect. Go on give it a treat.

- 1 Oil filter cartridge type (manual models) . . .GFE166£2.75
Oil filter paper element type (auto models) . .GFE104£4.50
- 2 Air filter element (998cc)GFE1008£4.96
- 3 Air filter element (1275cc)GFE1096£3.46
- 4 Spark plug (each) (1275cc)BPR6ES£4.90
Fan belt (1985 on)GCB10825£4.25
Contact set 45D distributorGCS118£2.15
Condenser 45D & 59D distributorGSC2109£2.45
- 5 Millers oil Trans M 5ltGGL4001X£40.96
Breather hose stepped12A1735£3.76

Carb. models brake parts (disc & drum)

Keep your brakes in tip top condition. Replace anything you think is worn with new! Better safe than sorry and at these prices why wouldn't you?

- 5 Front disc 8.4" diameter 12" wheelsGBD90806 . . .£10.50
- 6 Front disc pad set Mintex 8.4" disc (4 piece) . .GBP281 . . .£10.96
Rear brake drum with spacerGDB106Z . . .£21.95
Front or rear brake drum no spacerGDB105Z . . .£13.20
- 7 Rear brake shoe set Mintex (4 piece)GBS834AF . . .£11.95
Front brake shoe set (4 piece)GBS733AF . . .£14.20
- 8 Rear wheel cylinderGWC1102Z . . .£7.96

Carb. models suspension & running gear

We have all seen a Mini going down the road nose diving on the front driver's side! Or followed one that looks like it's driving side ways, you might even have

the problem yourself? Worn radius arm...a collapsed suspension cone or even just a worn knuckle joint. Give us a call we can help with the parts you need.

- 9 Suspension cone metric genuine RoverFAM3968 . . .£44.95
- 10 Radius arm complete RH OE newNAM7162N .£238.96
Radius arm complete LH OE newNAM7163N .£238.96
- 11 Front tie bar (each)21A450£8.15
- 12 Fulcrum pin front lower arm2A4362Z . . .£8.15
- 13 Outer CV joint (disc brake models)GCV1013 . . .£32.95
Upper arm repair kit2A4325K . . .£17.40
- 14 Swivel pin kits one side upper and lower . .GSJ166£7.25
- 15 Knuckle joint inc. gaiter and cup (each) . .GSV1118 . . .£2.80
- 16 Taper front wheel bearing kit (each)GHK1140 . . .£23.45
Taper rear wheel bearing kit (all models) (each) GHK1548 . . .£11.95

Carb. models general parts

MOT fails or just annoying niggles, some of the common culprits can be found here.

- Engine mounts (all models except auto)21A1902 . . .£3.25
- 17 Front subframe rear mounting21A2599Z . . .£3.20
Engine steady bar bush (fitted in pairs) . . .CRC5329 . . .£1.15
- 18 Track rod end (each)GSJ734Z . . .£5.26
Gaiter kit outer CV joint OE heavy duty . . .GSV1053 . . .£7.15
- 19 Water pump, with bypassGWP134 . . .£14.75
Steering rack gaiter kit OE steel clipsGSV1153 . . .£5.95
Rocker cover gasketGUG705009VC .£1.06
Inlet & exhaust manifold gasketAJM601 . . .£1.80
Thermostat standard 82°C (180°F)GTS104 . . .£3.95
Oil seal rod changeAHU1672 . . .£1.25
Oil seal diff. output shaftADU5738 . . .£1.25

SPI models

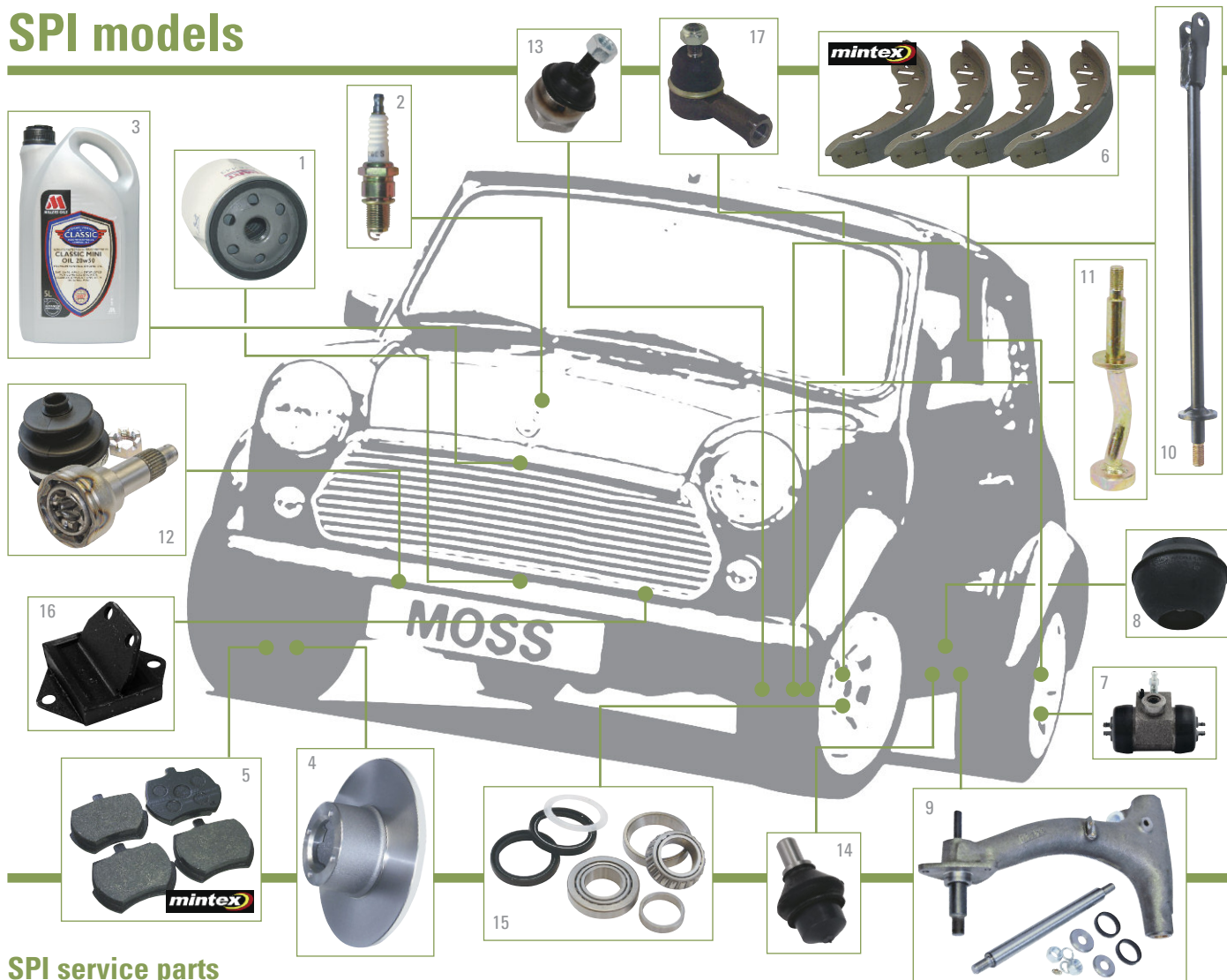

SPI service parts

Regular servicing is the best way to keep on top of your Mini. To ensure reliability as well as functionality use the best parts you can! Cheap oil and a dodgy filter might do more damage than you think.

- 1 Oil filter cartridge type (to 1996)GFE166£2.75
Air filter element (to 1996)GFE1143£6.46
Fuel filter 20mm outlet nut (to 1996)GFE7059£11.95
- 2 Spark plug (to 1996) (each)BPR6ES£4.90
Fan belt (to 1996)GCB10825£4.25
- 3 Millers oil Trans M 5ltGGL4001X ...£40.96

SPI brake parts

It's all well and good making your pride and joy go a little faster with the odd tuning part here and there, but will it stop? Quite often Mini brakes are totally neglected and in a sorry state, why not check them over and replace any worn components with new, it's not that expensive and could save a life!

- 4 Front disc 8.4" diameterGBD90806 ...£10.50
- 5 Front disc pads set Mintex (4 piece)GBP281£10.96
Rear brake drum spacedGDB106Z£21.95
- 6 Rear brake shoe set Mintex (4 piece)GBS834AF ...£11.95
- 7 Rear wheel cylinderGWC1102Z ...£7.96

SPI suspension & running gear

Crabbing, sagging and banging are all common terms used to describe the Classic Mini and people are usually referring to the suspension! Don't panic if you have any of the above problems we are here to help and have the parts and the solutions for you.

- 8 Suspension cone metric genuine RoverFAM3968 ...£44.95
- 9 Radius arm complete RH OE newNAM7162N .£238.96
Radius arm complete LH OE newNAM7163N .£238.96
- 10 Front tie bar (each)21A450£8.15
- 11 Fulcrum pin front lower arm2A4362Z£8.15
- 12 Outer CV jointGCV1013 ...£32.95
Upper arm repair kit2A4325K£17.40
- 13 Swivel pin kits one side upper and lower ...GSJ166£7.25
- 14 Knuckle joint inc: gaiter and cup (each) ...GSV1118£2.80
- 15 Taper front wheel bearing kit (each)GHK1140 ...£23.45
Taper rear wheel bearing kit (each)GHK1548 ...£11.95

SPI general parts

We all know Mini has it's problem areas, we usually find out what they are come MOT time! Here are some common parts that might need to be replaced.

- Engine mounts21A1902£3.25
- 16 Front subframe rear mounting21A2599Z£3.20
Engine steady bar bush (fitted in pairs)CRC5329£1.15
- 17 Track rod end (each)GSJ734Z£5.26
Gaiter kit outer CV joint OE heavy duty ...GSV1053£7.15
Water pump (no bypass)GWP187£17.30
Steering rack gaiter kit OE steel clipsGSV1153£5.95
Rocker cover gasketGUG705009VC .£1.06
Inlet & exhaust manifold gasketAJM601£1.80
Thermostat standard 88°C (190°F)GTS106£3.95
Oil seal rod changeAHU1672£1.25
Oil seal differential output shaftADU5738£1.25



MPI models

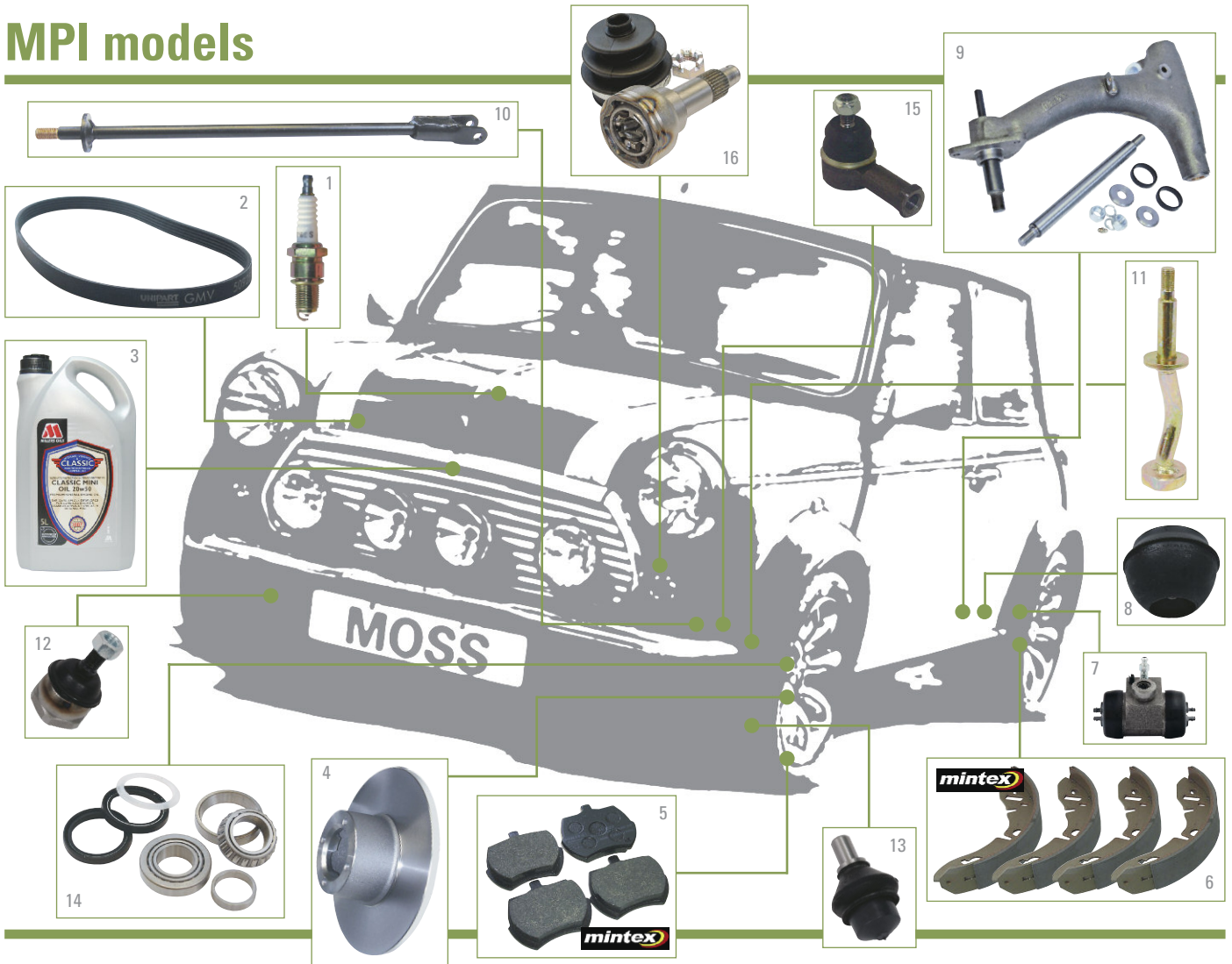

MPI service parts

Keeping your Mini's engine in top condition has to come high on the agenda, regular servicing with good quality parts is easy and doesn't need to cost a fortune! Prevention is always the better option.

- Oil filter cartridge type (1996 on)LPW100180 ..£4.25
- Air filter element (1996 on)GFE1143£6.46
- Fuel filter 20mm outlet nut (to 169573 chassis) .GFE7059£11.95
- Fuel filter (169574 chassis on)WJN101190 ..£13.96
- 1 Spark plugs (each) (1996 on)BPR6ES£4.90
- 2 Fan belt multi groove (1996 on)GMB50920 ..£12.60
- 3 Millers oil Trans M 5ltGGL4001X ..£40.96

MPI brake parts

One of the most important components on any car has to be the brakes! Mini is no exception to this. It's so important to check the condition of your brakes on a regular basis! If in doubt... replace with new parts.

- 4 Front disc 8.4" diameterGBD90806Z ..£10.50
- 5 Front disc pads set Mintex (4 piece)GBP281£10.96
- Rear brake drum spacedGDB106Z ..£21.95
- 6 Rear brake shoe set Mintex (4 piece)GBS834AF ..£11.95
- 7 Rear wheel cylinderGWC1102Z ..£7.96

MPI suspension parts & running gear

Knocks and bangs are quite common on Mini, usually caused by part of the suspension being badly worn. The MPI model does seem to suffer a little

more mainly due to the larger and wider wheels fitted. The common failure parts are listed below.

- 8 Suspension cone metric genuine RoverFAM3968 ...£44.95
- 9 Radius arm complete RH OE newNAM7162N .£238.96
- Radius arm complete LH OE newNAM7163N .£238.96
- 10 Front tie bar (each)21A450£8.15
- 11 Fulcrum pin front lower arm2A4362Z£8.15
- Upper arm repair kit2A4325K£17.40
- 12 Swivel pin kits one side upper and lower ...GSJ166£7.25
- 13 Knuckle joint inc: gaiter & cup (each)GSV1118£2.80
- 14 Taper front wheel bearing kit (each)GHK1140 ...£23.45

MPI general parts

Here are some of the parts we get asked for on a regular basis. Helping you to keep your Mini alive and in the best possible shape is why we are here and we are constantly checking not only our product but also our prices!

- Engine mounts21A1902£3.25
- Engine steady bar bush (fitted in pairs)CRC5329£1.15
- 15 Track rod end (each)GSJ734Z£5.26
- 16 Outer CV jointGCV1013 ...£32.95
- Gaiter kit outer CV joint OE heavy duty ...GSV1053£7.15
- Water pump, no bypassGWP187£17.30
- Steering rack gaiter kit OE steel clipsGSV1153£5.95
- Rocker cover gasketGUG705009VC .£1.06
- Inlet & exhaust manifold gasketLKJ100580EVA .£6.85

Ordering Information

Notification of prices

Due to the volatility of world markets and currency fluctuations the prices in this catalogue are subject to change. Moss make every attempt to keep prices competitive and stable, however in common with all other suppliers in our industry, we reserve the right to alter these prices without prior notice.

For the latest prices, please visit our website www.moss-europe.co.uk. All prices are per unit (unless otherwise stated) and include (UK) VAT at 20% (where applicable) and are correct at the time of going to print. Postage and packaging is not included. E&OE. Where the price is replaced with the word "£Call" this part is generally not available or only available to order. Please call our sales staff as we may be able to assist you in locating the part or a suitable replacement part.

Product supersessions

Moss Europe's policy is to detail the most up to date part information in our catalogues. Where possible parts are kept to original specification. However, in some instances we have to supersede to the most viable alternative product to maintain supply and keep cars on the road. Every effort is made to ensure high quality products.

UK ordering

We accept orders by mail, telephone, e-mail, fax and on-line at www.moss-europe.co.uk. If you have the opportunity, we invite you to visit one of our branches. Remember, supplying details of your car, (i.e. engine, commission or Vehicle Identification Number (VIN) LHD or RHD, year of manufacture and any modifications) saves time and helps us to help you. Please inform us of your customer number, as this will speed up the processing of your order.

Overseas ordering

We accept orders by mail, telephone, e-mail, fax and on-line at www.moss-europe.co.uk. If you visit the U.K. please come and visit one of our branches. When ordering, please ensure that you enclose full details of your name, address and customer number, plus details of your car (i.e. engine, commission or Vehicle Identification Number (VIN) LHD or RHD, year of manufacture and any modifications).

Please note: Overseas orders are often subject to local import duties, taxes and Customs clearance, which will need to be paid for at the point of entry. These charges are NOT included in the price of the goods or delivery prices. All relevant Customs forms and documentation needed to ensure the order arrives with the minimum of delay, will be included with your shipment. If you have any special requirements, please contact us to discuss them. Delivery charges are dependent upon the size and weight of the shipment. If a quotation is required prior to placing an order, please contact the export department at your chosen branch and they will be pleased to supply a full quotation.

Parts back-order system

A back-order system is used when a part is not in stock at the time of ordering. If the item is expected to become available within 6 months, then it will be put on back-order, unless the customer instructs us otherwise. When we have the parts in stock, the back-order will be processed automatically and the item will be dispatched to the customer. If the particular part becomes No Longer Available (NLA) or does not become available within 6 months the back-order will be cancelled. If you are unsure when you placed a back-order contact your local branch.

Dispatch & delivery methods

Orders for delivery in the UK may be dispatched by regular post (for small/lightweight items), or through a Next Day courier. Please contact us for the best delivery option for your order. We are constantly striving to improve the service we offer, so please contact us for the latest delivery prices. For delivery outside the UK we offer the following services:

- **Economy delivery (by road):** 2 to 5 days.
- **Express delivery (by air):** 1 to 2 days (Guaranteed) - next day service to most countries.
- **For small and low value orders we also use airmail.**

For these services, please ask for prices and the best delivery option when you place your order. Most deliveries (except airmail) are 'trackable', (inc: e-mail updates and internet access for selected carriers). Please remember, all carriage charges are dependent on weight band, volume, destination and delivery time. If a quotation is required prior to placing your order, please contact a member of the sales department. Alternatively, you can arrange your own delivery and dispatch.

Windscreens delivery information

We always suggest that windscreens should be collected from one of our branches to ensure you are able to transport your glass with the utmost of care. However, we understand that this is not always possible.

To minimise the possibility of damage to the windscreen in the shipping process, it is now Moss Europe's policy to ship windscreens packed in a specially designed heavy duty 'Tri-Wall' cardboard box. The price of this box is £35.00 (inc VAT), non-refundable and is included in the price of the product. The crate's dimensions will also increase shipping costs, particularly in EU countries. The crate dimensions are 150cm x 33cm x 74cm. The maximum volumetric weight is 92kgs. For more information please contact your nearest Moss branch.

Hazardous goods delivery information

At the time of going to print, Moss Europe Ltd conforms to international shipping regulations regarding packaging and transportation of Hazardous Goods by road and sea freight (only). Due to these international shipping regulations and licencing rules all goods deemed as Hazardous are currently available for shipping to the UK and Europe only. If you place an order containing Hazardous goods and your shipping address is not in the UK or Europe, we will not be able to ship this item to you. Please contact your local branch or visit our website www.moss-europe.co.uk for the latest delivery information of Hazardous goods.

Quotations & payment methods

We will be pleased to provide a full parts quotation detailing price, availability and relevant shipping costs. Payment may be made by cash, personal cheque (to the card guarantee limit), Certified Bank Draft, Sterling Travellers Cheques and credit or debit card including: Mastercard, Visa, Delta. If you intend to make payment by Cheque or Bankers Draft when

using our fast mail-order parts service, please confirm parts availability and carriage charges. We can accept payments using PayPal for email and phone orders only.

Value added tax (VAT)

Value Added Tax (VAT) at the current rate will be levied on all orders being dispatched to all countries within the European Community. EU countries may be charged at their local VAT rate, please contact us or see website for details. VAT is not charged on goods dispatched to countries outside of the EU. However, such orders are often subject to local import duty, taxes and Customs clearance, which MUST be paid by you at the port of entry. Such charges are not included in the cost of the goods or delivery prices.

Exchange units

We are able to offer a full rebuild service on numerous major components in our product range. We offer this service as an alternative to direct replacement parts, or when a brand new item is no longer available. However, the continuity of this exchange scheme needs the understanding and co-operation of our customers in relation to several important points: It is important to remember that "rebuild" does not mean "brand new". Rebuilding a unit involves stripping, cleaning, inspecting and re-assembling the unit. During this process, parts showing signs of wear will either be completely replaced or suitably renovated. However, it is not always feasible for major sub-components to be replaced with brand new ones, for example, an exchange engine will not have a new block. Due to the nature of certain product lines, some items can only be offered on a "one for one" exchange basis. This effectively means that you must offer us a viable unit before we can release a fully rebuilt item from our stock. In some instances we can only carry out reconditioning of your own unit. Our staff will inform you if this is the case.

All exchange units are subject to a surcharge. This surcharge serves two purposes; firstly, it acts as an incentive for you to return your old unit, and secondly it provides us with financial cover if your returned unit proves unsuitable for exchange purposes.

Whether or not your returned unit is suitable for exchange purposes cannot be ascertained until it is made available to us for inspection. As a general rule, suitable for exchange basically excludes any items that are beyond reasonable repair (e.g. crankcases pierced by a connecting rod) or units irrevocably damaged. We are also unable to accept units unless they are returned in whole, complete form (i.e. differential units which are returned partly stripped with no bearings and all the shims missing are not generally accepted), nor do we accept a "box of bits".

Surcharges will only be refunded once our core department has passed the item as serviceable. Under no circumstances can any exchange unit be shipped overseas until we receive your original unit. We have predetermined prices for our exchange units based on our experience of repair costs for a gearbox, axle or engine. Occasionally, however, the damage to the unit is so great that we will contact you before beginning work on your unit to advise you of any additional cost that may be incurred during the rebuild of the unit. We can return the unit (at your cost) if this proves unacceptable.

'Old unit' returns

Exchange items including reconditioned engines are subject to a surcharge that is refunded when a rebuildable unit (core) is returned. When you receive the rebuilt unit, attached to it will be a Core Return Authorisation Tag. This tag must be removed from the rebuilt unit and attached to the returned core in order to receive credit. Cores must be returned within 90 days of purchase in the original box, carton or engine cradle supplied with the rebuilt unit. Cores must be shipped clean and empty of fluids. Cores must be complete, assembled and rebuildable to receive credit or refund. You must pay all shipping charges for the return of the core and these charges are not refundable.

Warranty

All parts are warranted against defects in materials and workmanship for a period of twelve (12) months from the date of purchase. The warranty does not cover failure resulting from incorrect installation or misuse; failure during any competition, motorsports or track events; failure of any, or caused by any, related component. The warranty does not cover labour charges, nor will a warranty settlement be greater than the cost of the original component. Should you need to make a warranty claim, please contact us immediately at the branch of purchase. We will then advise you as to the best course of action. With all warranty claims a copy of the original purchase invoice must be produced.

Warranty returns

Parts that fail in use may be returned for 12 months from the date of purchase. Returns must be accompanied by the original invoice - no warranty claims will be paid without a copy of the original invoice. Return freight will be reimbursed. Electrical parts returned for warranty will be tested and if found functional, no return credit will be given and the part will be returned. Reimbursement is made by the original payment method. Complete the return form included in each order, pack the items securely and use the shipping return label supplied.

Non-warranty returns

All uninstalled parts, in their original packaging may be returned within 90 days for any reason. A copy of the original invoice or the picking label (which is generally attached to the original packaging) must accompany the return. Return freight is paid by the customer. If the return is due to our error, the return freight will be reimbursed. Parts returned outside of this policy or in non-resalable condition may not be accepted or may be assessed a 15% handling fee. Reimbursement is made by the original payment method. Complete the return form included in each order, pack the items securely and use the shipping return label supplied.

Customer service

We value your custom and wish to ensure that you receive the very best service. Every effort will be made to provide you with Quality Parts and Expertise in a relaxed, helpful and friendly manner. Should you consider the service you receive from us to be unsatisfactory, or you have any problems with the part(s) purchased, please advise a member of the sales team at the originating branch. If the matter is not resolved to your satisfaction, please e-mail our Customer Services Department at customerservices@moss-europe.co.uk or write to: **Customer Services, Moss Europe Ltd Unit 16, Hampton Business Park, Bolney Way, Feltham TW13 6DB England.** We will do our very best to resolve the issue.

British Motor Heritage

Moss Europe Ltd is a British Motor Heritage approved specialist. Our agreement with British Motor Heritage allows us the use of marque logos and some of the artwork contained within this catalogue.

